

## DESIGN FEATURES

- Built-in ISO 5211 Direct Mounting Pad Easy Automation
- Anti-static Devices for Ball-Stem-Body
- Blow-out Proof Stem
- Positive Position location at 90° Increments
- Locking in Every 90° Increments
- TA-Luft Design Approved
- NACE standard MR0175 & MR0103 (Optional)
- Casting Approved by TÜV AD 2000-Merkblatt W0
- Options : 1.Actuator 2.Limit Switch 3.Positioner



## APPLICABLE STANDARDS

- Design Standard : MSS SP-110
- Wall Thickness : EN12516-3
- Pipe Thread : ASME B1.20.1, BS21, EN 10226  
DIN 2999/259, ISO 228/1  
JIS B0203 ISO 7/1
- Inspection & Testing : MSS SP-110

## TORQUE VALUES

Close to Open Torque at Various Differential Pressure ( $\Delta P$ ), Standard Seats (TFM1600 & PTFE)

unit : in-lb / N-m

Size/ $\Delta P$		75 psig		150 psig		300 psig		700 psig		1000 psig	
		5 bar		10 bar		20 bar		50bar		63bar	
NPS	DN	N-m	In-lb	N-m	In-lb	N-m	In-lb	N-m	In-lb	N-m	In-lb
1/4	8	9	80	9	80	9	80	9	80	9	80
3/8	10	9	80	9	80	9	80	9	80	9	80
1/2	15	9	80	9	80	10	88	10	88	10	88
3/4	20	14	124	14	124	15	133	15	133	15	133
1	25	18	159	18	159	19	168	22	195	25	221
1 1/4	32	25	221	26	230	27	239	33	292	36	319
1 1/2	40	35	310	38	336	42	372	46	407	50	442

Remark :

- 1.The torque figures at 5 bar pressure are maximum values to be tested after the valves are placed for 24 hours.
- 2.For actuator sizing, a safety factor of minimum 30% is recommended.

## TECHNICAL INFORMATION

### PRESSURE - TEMPERATURE DATA

The pressure-temperature data of ball valves are determined not only by valve shell materials but also by sealing materials used for ball seats, gland packings and flange gaskets.

Full Bore: NPS 1/4 to NPS 1  
DN8 to DN25

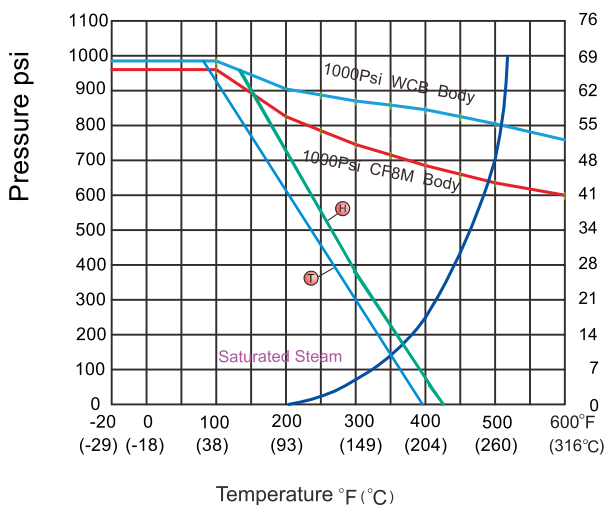

Full Bore: NPS 1 1/4 to NPS 1 1/2  
DN32 to DN40

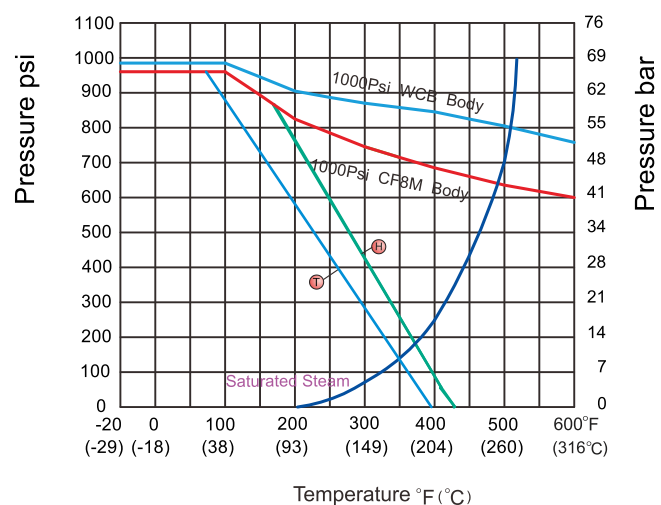

Seat Materials : PTFE TFM1600

Body Ratings: Shown above are for ASTM A351 Gr.CF8M and A216 Gr.WCB

For ratings of other valve shell materials, please refer to the last edition of ASME B16.34.

**100WOG, High Performance  
3-Way Full Port Threaded End Ball Valve**

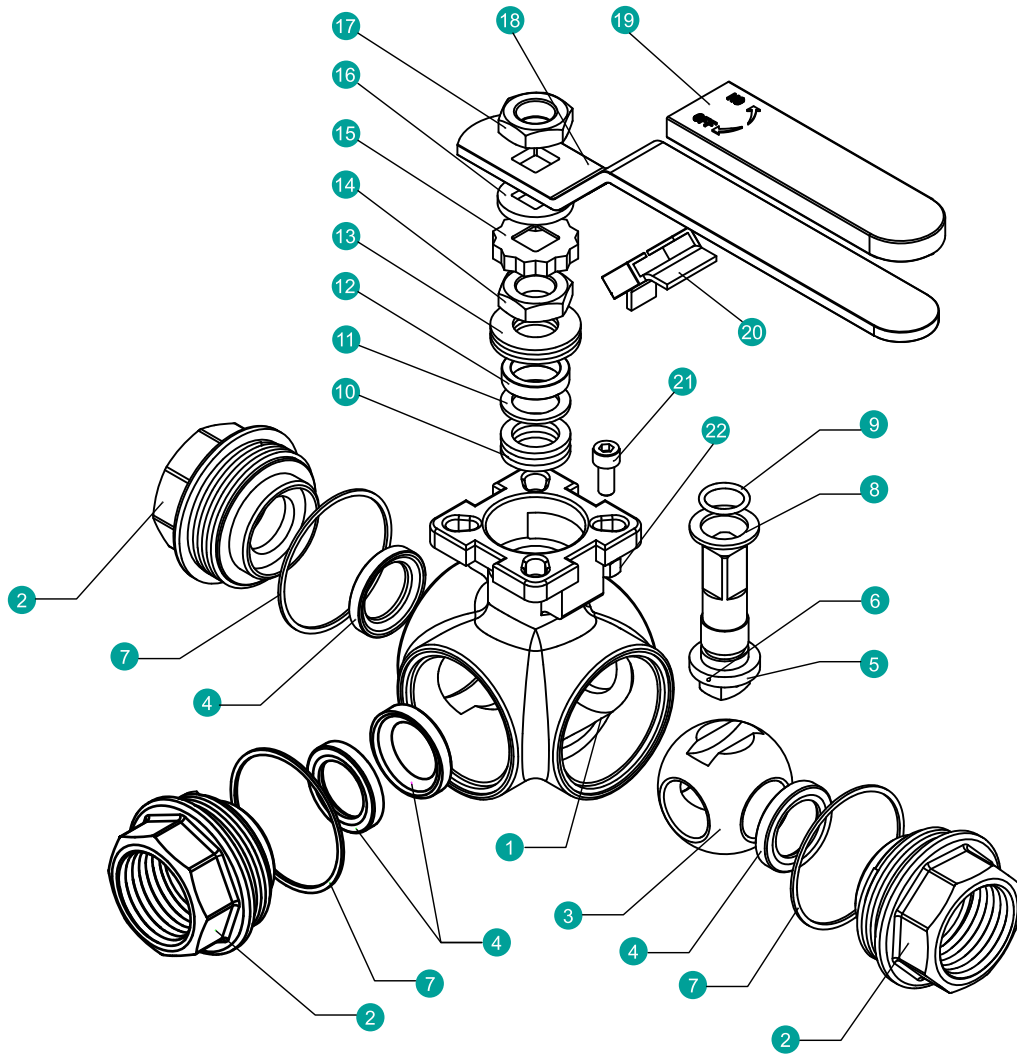

**MATERIAL OF CONSTRUCTION**

NO.	PART NAME	MATERIALS		
1	Body	CF8M(1.4408)	CF8(1.4308)	WCB(1.0619)
2	End Cap (Thread)	CF8M(1.4408)	CF8(1.4308)	WCB(1.0619)
3	Ball	316	304	
4	Ball Seat	TFM1600 /PTFE		
5	Washer	316	304	
6	Stem (Anti-Static)	316	304	
7	Body Gasket	PTFE/ GRAPHITE*		
8	Thrust washer	PTFE/ TFM1600		
9	O-Ring	FKM		
10	Packing	PTFE/ GRAPHITE*		
11	Bushing	50%SS+50%PTFE / 304*		
12	Gland	316		
13	Belleville Washer	301		
14	Stem Nut	A194-8		
15	Stop-lock-Cap	304		
16	Handle Gland	304		
17	Handle Nut	A194-8		
18	Handle	304		
19	Handle Sleeve	PVC		
20	Lock Device	304		
21	Stop Bolt	A2-70		
22	Stop Nut	A2-70		

**1000WOG, High Performance  
3-Way Full Port Threaded End Ball Valve**

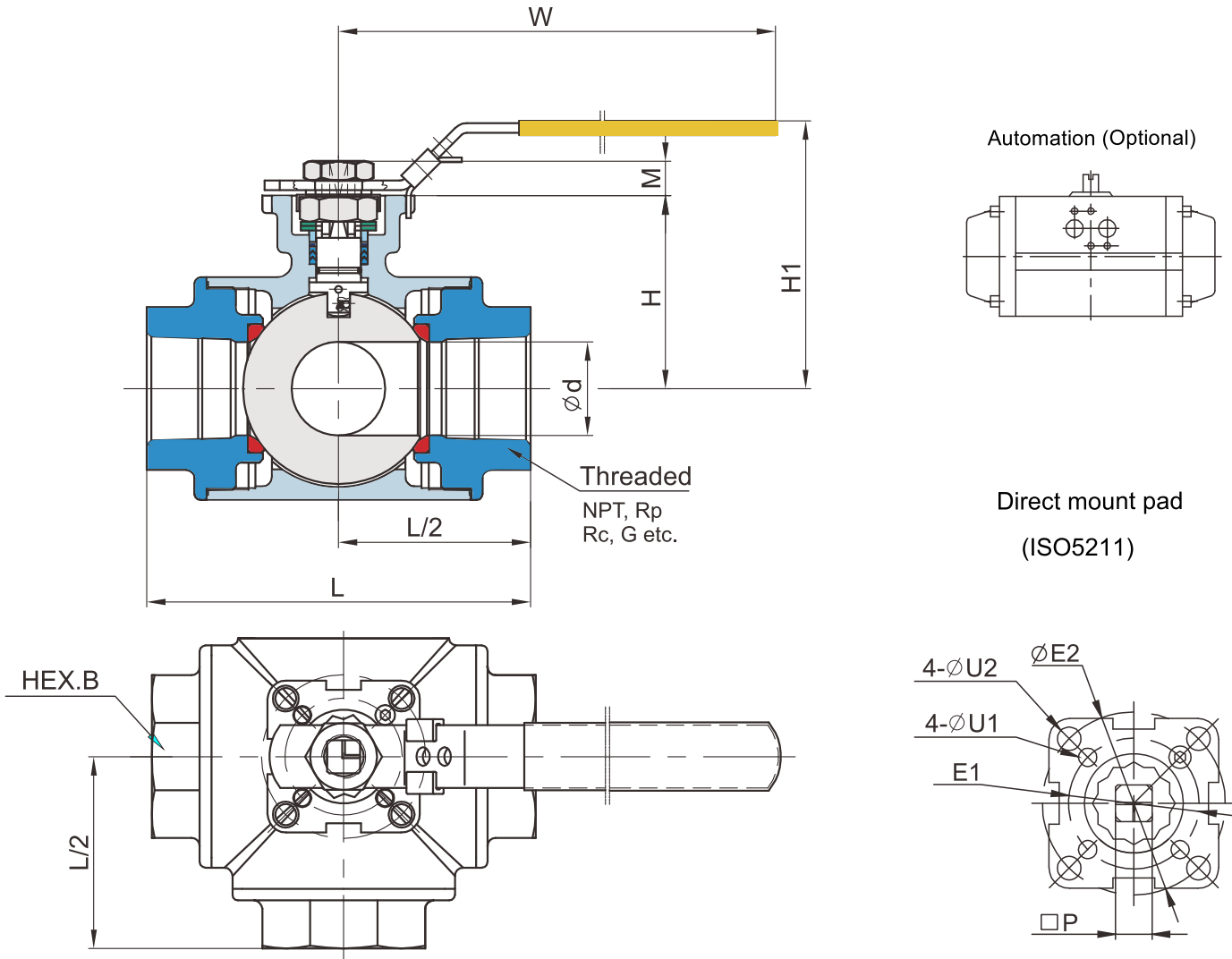

**DIMENSION TABLE**

**ANSI 1000 WOG DIMENSION TABLE**

Unit : mm

DN	NPS	d	L	H	H1	W	P	M	E1	E2	U1	U2	HEX.B	ISO 5211
8	1/4	11	79	43.0	73	147	9	9	36	42	6	6	22	F03~F04
10	3/8	11	79	43.0	73	147	9	9	36	42	6	6	23.5	F03~F04
15	1/2	15	88	49.0	79	147	9	9	36	50	6	7	27	F03~F05
20	3/4	20	108	59.5	91	177	11	11	42	50	6	7	34	F04~F05
25	1	25	124	63.0	93	177	11	11	42	70	6	9	41	F04~F07
32	1 1/4	32	135	73.5	105	215	14	14	50	70	7	9	50	F05~F07
40	1 1/2	40	164	82.8	115	215	14	14	50	70	7	9	56	F05~F07

Unit : inch

DN	NPS	d	L	H	H1	W	P	M	E1	E2	U1	U2	HEX.B	ISO 5211
8	1/4	0.43	3.11	1.69	2.87	5.79	0.354	0.354	1.42	1.65	0.24	0.24	0.87	F03~F04
10	3/8	0.43	3.11	1.69	2.87	5.79	0.354	0.354	1.42	1.65	0.24	0.24	0.93	F03~F04
15	1/2	0.59	3.46	1.93	3.11	5.79	0.354	0.354	1.42	1.97	0.24	0.28	1.06	F03~F05
20	3/4	0.79	4.25	2.34	3.54	6.97	0.433	0.433	1.65	1.97	0.24	0.28	1.34	F04~F05
25	1	0.98	4.88	2.48	3.66	6.97	0.433	0.433	1.65	2.76	0.24	0.35	1.61	F04~F07
32	1 1/4	1.26	5.31	2.89	4.13	8.46	0.551	0.551	1.97	2.76	0.28	0.35	1.97	F05~F07
40	1 1/2	1.57	6.46	3.26	4.53	8.46	0.551	0.551	1.97	2.76	0.28	0.35	2.20	F05~F07

## FLOW PATTERNS FOR 3 WAY VALVE

### T-PORT 90° TURN

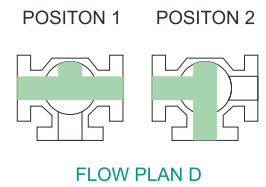
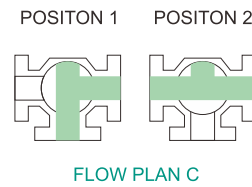
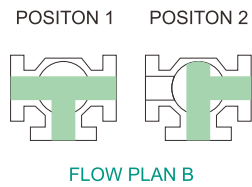
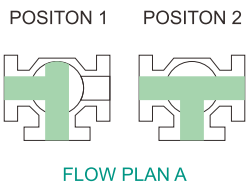

### T-PORT 180° TURN

