

Applicable Standards:

- Design:ASME B16.34, BS 6364
- Face to Face:ASME B16.10
- Flange Ends:ASME B16.5
- Wall Thickness:ASME B16.34
- Inspection & Testing:API 598,BS 6364
- Temperature:-196°C ≤ T ≤ +150°C

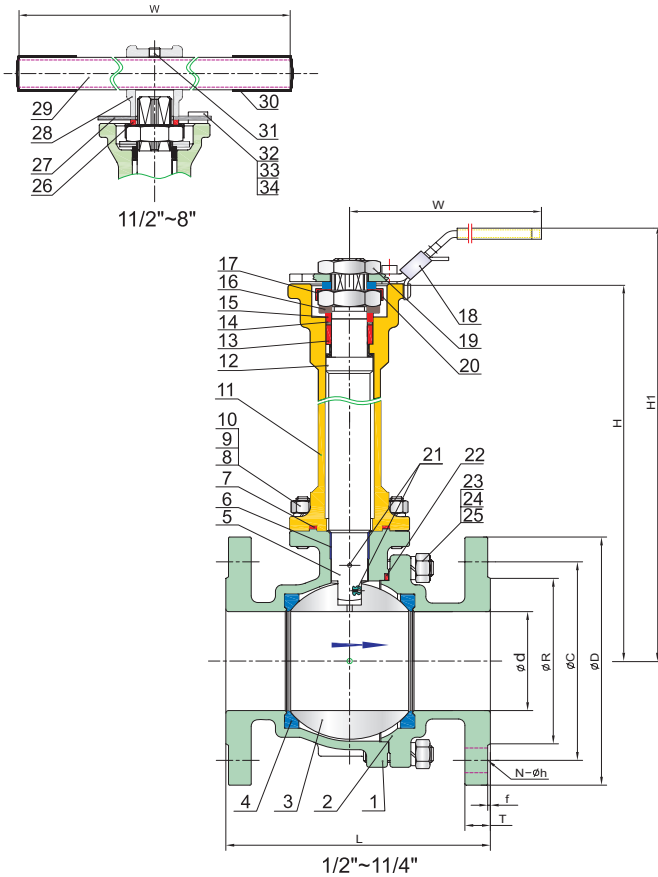

No.	Parts Name	Material	
1	Body	CF8M	CF8
2	Cap	CF8M	CF8
3	Ball	CF8M	CF8
4	Ball Seat	PTFE	
5	Stem	F316	F304
6	Stem Sleeve	50%SS+50%PTFE	
7	Gasket 1	TFM1600/316 Spiral Wound + Grafoil*	
8	Bolt	A320-B8	
9	Nut	A194-8	
10	Bushing	304	
11	Extention Bonnet	F316	F304
12	Sleeve	50%SS+50%PTFE	
13	Stem Packing	TFM1600/Grafoil*	
14	Bushing	304	
15	Gland	316	304
16	Belleville Washer	301	
17	Stem Nut	A194-8	
18	Lever(DN15~DN32)	CF8	
19	Lever Nut(DN15~DN32)	A194-8	
20	Stem Bushing	304	
21	Anti-Static Device	304	
22	Gasket 2	TFM1600/316 Spiral Wound + Grafoil*	
23	Bolt	A320-B8	
24	Nut	A194-8	
25	Washer	304	
26	Square slot bushing (DN40~DN200)	304	
27	Stop-lock Cap(DN40~DN200)	420	
28	Handle Adaptor(DN40~DN200)	CF8	
29	Pipe Handle(DN40~DN200)	A53+Zn Plated	
30	Lever Sleeve(DN40~DN200)	VINYL PLASTIC	
31	Set screw (DN40~DN200)	304	
32	Stop Bolt (DN40~DN200)	304	
33	Nut(DN40~DN200)	A2-70	
34	Washer(DN40~DN200)	304	

*Materials for Fire-Safe Type

ASME CLASS 150

KV-C41

Unit:mm

SIZE	d	L	R	C	D	f	T	N	h	W	H	H1	ISO 5211
1/2"	15	108	35	60.5	90	2	10.0	4	16	175	290	322	F05
3/4"	20	117	43	69.9	100	2	10.9	4	16	175	293	325	F05
1"	25	127	51	79.4	110	2	11.6	4	16	190	318	350	F07
1-1/4"	32	140	64	88.9	115	2	13.2	4	16	190	323	355	F07
1-1/2"	38	165	73	98.4	125	2	14.7	4	16	300	365	393	F10
2"	50	178	92	120.7	150	2	16.3	4	19	300	372	400	F10
2-1/2"	63.5	190	105	139.7	180	2	17.9	4	19	400	457	492	F10
3"	76	203	127	152.4	190	2	19.5	4	19	400	465	500	F10
4"	100	229	157	190.5	230	2	24.3	8	19	600	580	650	F12
5"	125	356	186	215.9	255	2	24.3	8	22.3	600	633	703	F12
6"	150	394	216	241.3	280	2	25.9	8	22.3	800	700	780	F16
8"	200	457	270	298.5	345	2	29.0	8	22.3	800	750	830	F16

ASME CLASS 300

KV-C42

Unit:mm

SIZE	d	L	R	C	D	f	T	N	h	W	H	H1	ISO 5211
1/2"	15	140	35	66.7	95	2	14.7	4	16	175	290	322	F05
3/4"	20	152	43	82.6	115	2	16.3	4	16	175	293	325	F05
1"	25	165	51	88.9	125	2	17.9	4	22.3	190	318	350	F07
1-1/4"	32	178	64	98.4	135	2	19.5	4	22.3	190	323	355	F07
1-1/2"	38	190	73	114.3	155	2	21.1	4	22.3	300	365	393	F10
2"	50	216	92	127.0	165	2	22.7	8	19	300	372	400	F10
2-1/2"	63.5	241	105	149.2	190	2	25.9	8	22.3	400	457	492	F10
3"	76	283	127	168.3	210	2	29.0	8	22.3	400	465	500	F10
4"	100	305	157	200.0	255	2	32.2	8	22.3	600	580	650	F12
5"	125	381	186	235.0	280	2	35.4	8	22.3	600	633	703	F12
6"	150	403	216	269.9	320	2	37.0	12	22.3	800	700	780	F16
8"	200	502	270	330.2	380	2	41.7	12	25.4	800	750	830	F16