

HIGH PERFORMANCE FLANGED BALL VALVE

Fire Safe / ATEX

TA-Luft / ISO15848-1 Approved

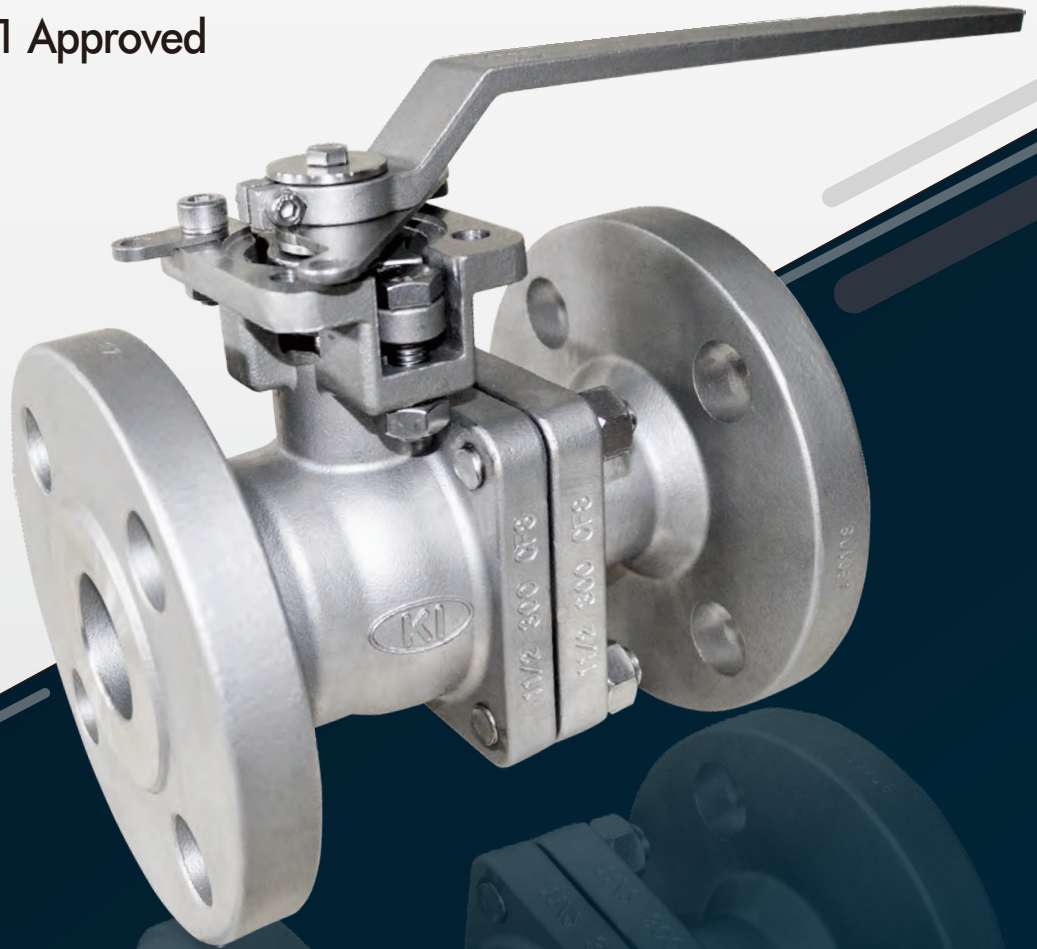

API 608 Compliance

- ➔ **ASME Class 150/300**
- ➔ **KV-L441 / KV-L442**
- ➔ **KV-L641 / KV-L642 (Fire Safe Type)**

Applicable Standards

- Design Standard : ASME B16.34 API 608
- Fire Safe Design : API 607 7th 2016
- Face To Face : ASME B16.10
- Flanged End : ASME B16.5 Class 150 / 300
- Inspection & Testing : API 598

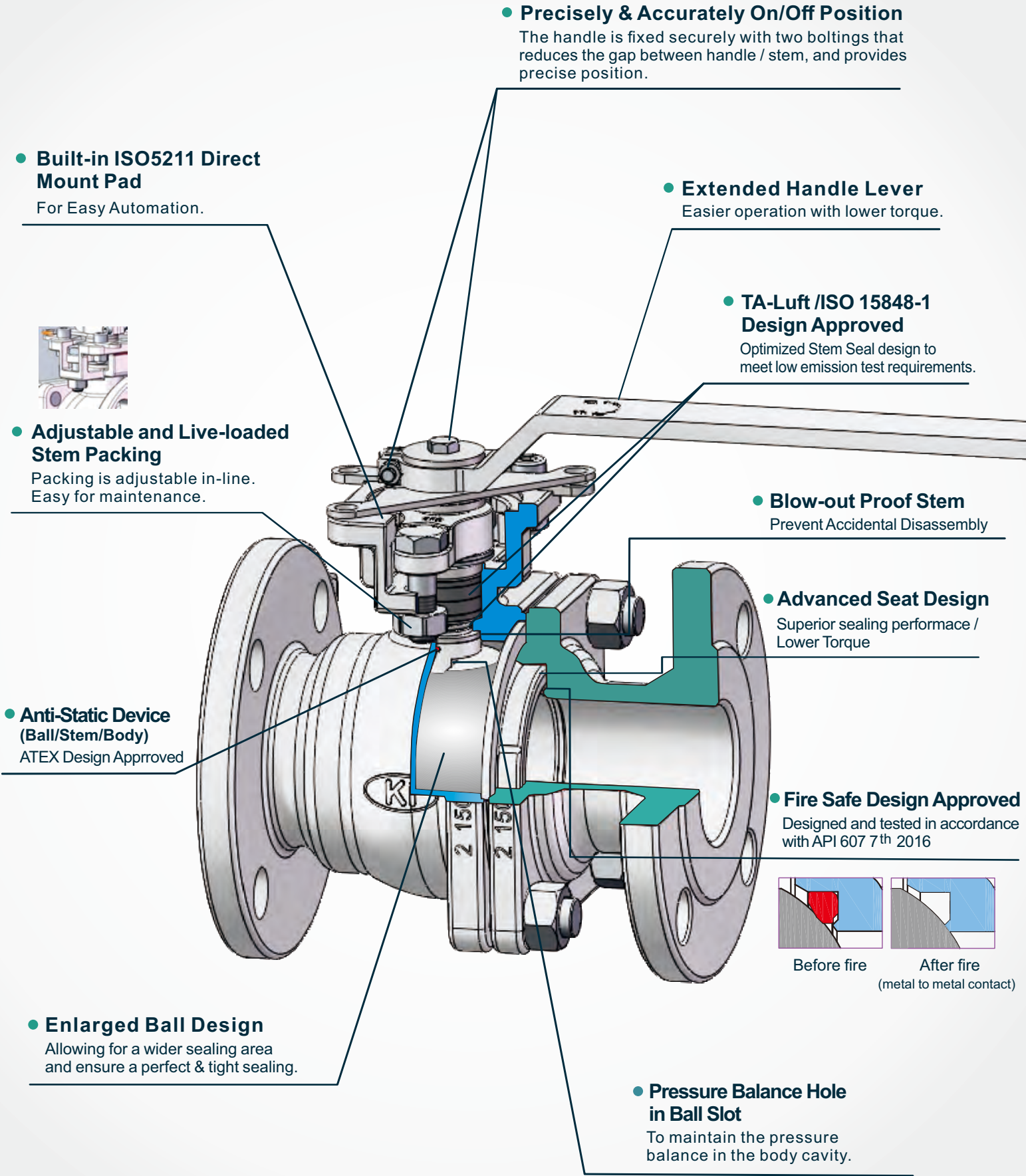

DESIGN FEATURES

- Built-in ISO 5211 Direct Mounting Pad Easy Automation
- Fire Safe Design Approved
- Anti-static Devices for Ball-Stem-Body
- Blow-out Proof Stem
- Pressure Balance Hole in Ball Slot
- Adjustable and live-loaded stem packing
- ISO 15848-1 Design Approved
- NACE standard MR0175 & MR0103 (Optional)
- Casting Approved by TÜV AD 2000-Merkblatt W0
- Options : 1.Actuator 2.Limit Switch 3.Positioner



APPLICABLE STANDARDS

- Design Standard : ASME B16.34 API 608
- Frie Design : API 607 7th 2016
- Face To Face : ASME B16.10
- Flanged End : ASME B16.5 Class 150 / 300
- Inspection & Testing : API 598

CV VALUES

NPS	CV	
	Class 150	Class 300
1/2	30	30
3/4	55	55
1	96	96
1 1/4	170	170
1 1/2	270	270
2	470	470
2 1/2	780	780
3	1150	1150
4	2100	2100
5	3500	3500
6	5000	5000
8	9500	9500

WEIGHT

NPS	KV-L441/KV-L641		KV-L442/KV-L642	
	Weight (kg)	Weight (lb)	Weight (kg)	Weight (lb)
1/2	2.6	5.7	3.4	7.5
3/4	3.0	6.6	4.6	10.1
1	4.0	8.8	5.5	12.1
1 1/4	5.1	11.2	7.4	16.3
1 1/2	6.8	15.0	10.8	23.8
2	10.8	23.8	13.5	29.8
2 1/2	17	37.5	21.8	48.1
3	23.2	51.1	31.6	69.7
4	36.6	80.7	50	110.2
5	62.1	136.9	82	180.8
6	84	185.2	109	240.3
8	161	354.9	211	465.2

TORQUE VALUES

Close to Open Torque at Various Differential Pressure (ΔP), Standard Seats (TFM1600&PTFE)

ASME Class 150

KV-L441, KV-L641

unit : in-lb / N·m

Size / ΔP		5 bar		10 bar		20 bar	
		N·m	In-lb	N·m	In-lb	N·m	In-lb
1/2	DN15	5	44	5	44	5	44
3/4	DN20	6	53	6	53	6	53
1	DN25	11	97	11	97	12	106
1 1/4	DN32	14	124	14	124	16	142
1 1/2	DN40	21	186	21	186	24	212
2	DN50	28	248	32	283	35	310
2 1/2	DN65	44	389	50	443	54	478
3	DN80	78	690	86	761	97	858
4	DN100	112	991	132	1168	146	1292
5	DN125	209	1850	231	2044	270	2390
6	DN150	336	2974	367	3248	408	3611
8	DN200	444	3929	516	4567	584	5168

- Remark :
1. Torques will increase about 30% if seat materials are Reinforced Fiber-Glass PTFE, Carbon-filled PTFE or EK+PTFE or EK+PTFE or TFM4215.
 2. The torque figures at 5 bar pressure are maximum values to be tested after the valves are placed for 24 hours.
 3. For actuator sizing, a safety factor of minimum 30% is recommended.
 4. KI reserve the right to revise this information without the notice.

ASME Class 300

KV-L442, KV-L642

unit : in-lb / N·m

Size / ΔP		5 bar		10 bar		20 bar		50 bar	
		N·m	In-lb	N·m	In-lb	N·m	In-lb	N·m	In-lb
1/2	DN15	5	44	5	44	5	44	5	44
3/4	DN20	6	53	6	53	6	53	6	53
1	DN25	11	97	11	97	12	106	13	115
1 1/4	DN32	14	124	14	124	16	142	17	150
1 1/2	DN40	21	186	21	186	24	212	26	230
2	DN50	28	248	32	283	35	310	39	345
2 1/2	DN65	44	389	50	443	54	478	60	531
3	DN80	82	726	90	797	101	894	113	1000
4	DN100	117	1035	138	1221	153	1354	170	1505
5	DN125	219	1938	242	2142	284	2513	359	3177
6	DN150	352	3115	385	3407	428	3788	667	5903
8	DN200	466	4124	541	4788	613	5425	957	8469

- Remark :
1. Torques will increase about 30% if seat materials are Reinforced Fiber-Glass PTFE, Carbon-filled PTFE or EK+PTFE or EK+PTFE or TFM4215.
 2. The torque figures at 5 bar pressure are maximum values to be tested after the valves are placed for 24 hours.
 3. For actuator sizing, a safety factor of minimum 30% is recommended.
 4. KI reserve the right to revise this information without the notice.

TECHNICAL INFORMATION

PRESSURE - TEMPERATURE DATA

The pressure-temperature data of ball valves is determined not only by valve shell materials but also by sealing materials used for ball seats, gland packings and flange gaskets.

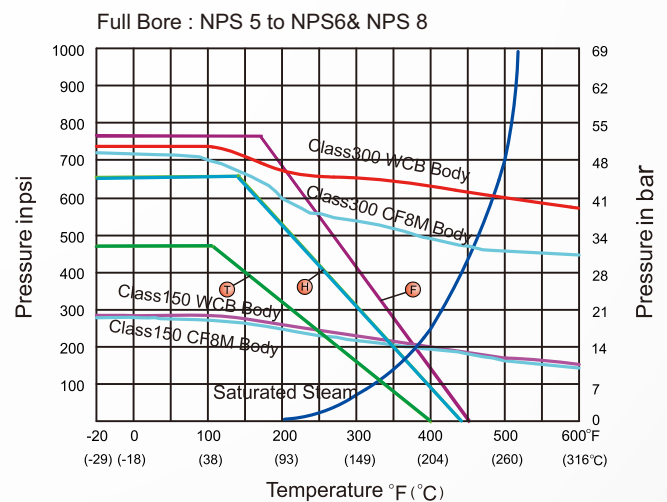
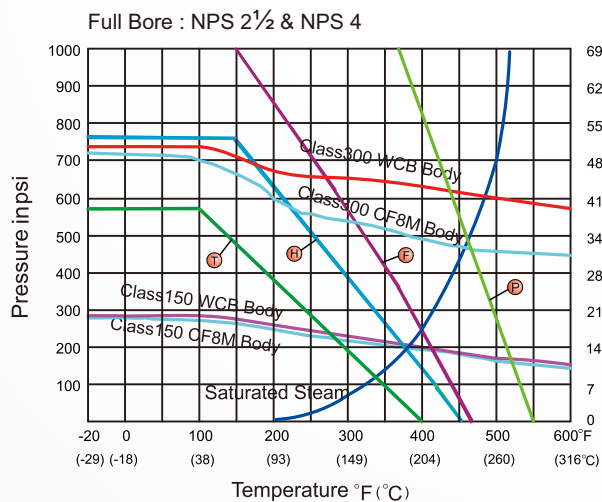
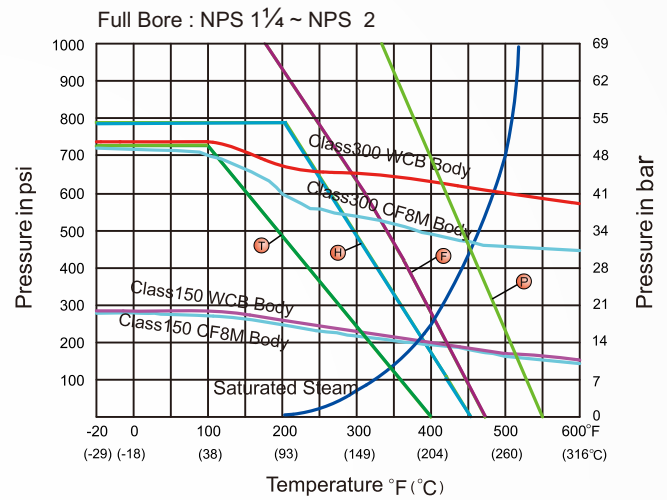
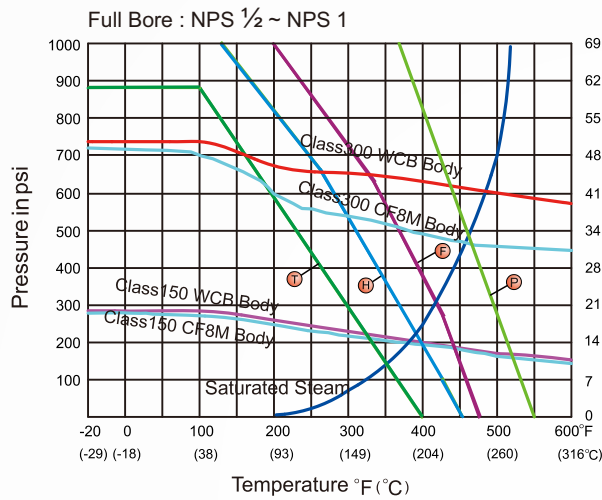

Body Ratings: Shown above are for ASTM A351 Gr.CF8M and A216 Gr.WCB

For ratings of other valve shell materials, please refer to the last edition of ASME B16.34.

Seat Materials : T PTFE H TFM1600 F TFM4215 P PEEK

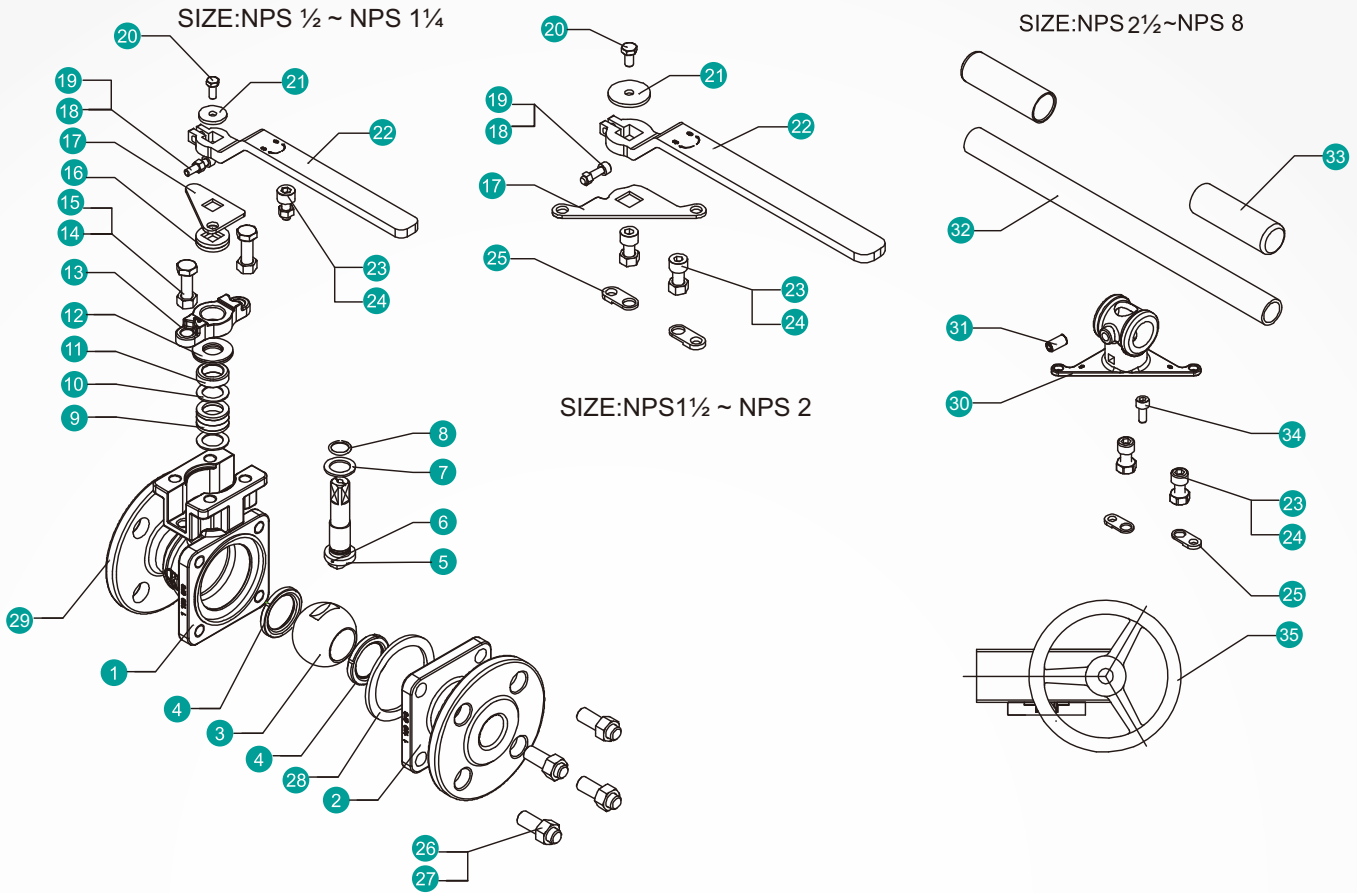

MATERIAL OF CONSTRUCTION

NO.	PART NAME	MATERIALS		
1	Body	A351-CF8M	A351-CF8	A216-WCB
2	End Cap	A351-CF8M	A351-CF8	A216-WCB
3	Ball	316		304
4	Ball Seat	TFM1600 / PTFE / TFM4215		
5	Stem	316		304
6	Anti-Static	316		304
7	Thrust Washer	PTFE/TFM1600		
8	O-Ring	FKM		
9	Packing	PTFE / GRAPHITE*		
10	Bushing	50%SS+50%PTFE / 304*		
11	Gland	316		304
12	Belleville Washer	301		
13	Packing Gland	A351-CF8		
14	Bolting	A2-70		8.8
15	Bolt Nut	A2-70		8
16	Support Washer (NPS 1/2 ~ NPS 2)	304		
17	Stem Stopper (NPS 1/2 ~ NPS 2)	304		
18	Bolting (NPS 1/2 ~ NPS 2)	A2-70		
19	Bolt Nut (NPS 1/2 ~ NPS 2)	A2-70		
20	Bolting (NPS 1/2 ~ NPS 2)	A2-70		
21	Washer (NPS 1/2 ~ NPS 2)	304		
22	Handle (NPS 1/2 ~ NPS 2)	CF8		
23	Stop Bolt	A2-70		
24	Stop Nut	A2-70		
25	Lock Device (NPS 1 1/2 ~ NPS 8)	304		
26	Bolting	A193-B8		A193-B7
27	Bolt Nut	A194-8		A194-2H
28	Body Gasket	PTFE (304)/ 316 Spiral Wound+Graphite*		
29	Nameplate	304		
30	Handle Adapter(NPS 2 1/2 ~ NPS 8)	A351-CF8		
31	Set Screwed (NPS 2 1/2 ~ NPS 8)	A2-70		
32	Pipe Handle (NPS 2 1/2 ~ NPS 8)	A53+PLATED Zn		
33	Handle Sleeve (NPS 2 1/2 ~ NPS 8)	PVC		
34	Bolting (NPS 2 1/2 ~ NPS 8)	A2-70		
35	Worm Gear (Optional)	Package		

*Materials for KV-L641, KV-L642 Series (Fire Safe Models)

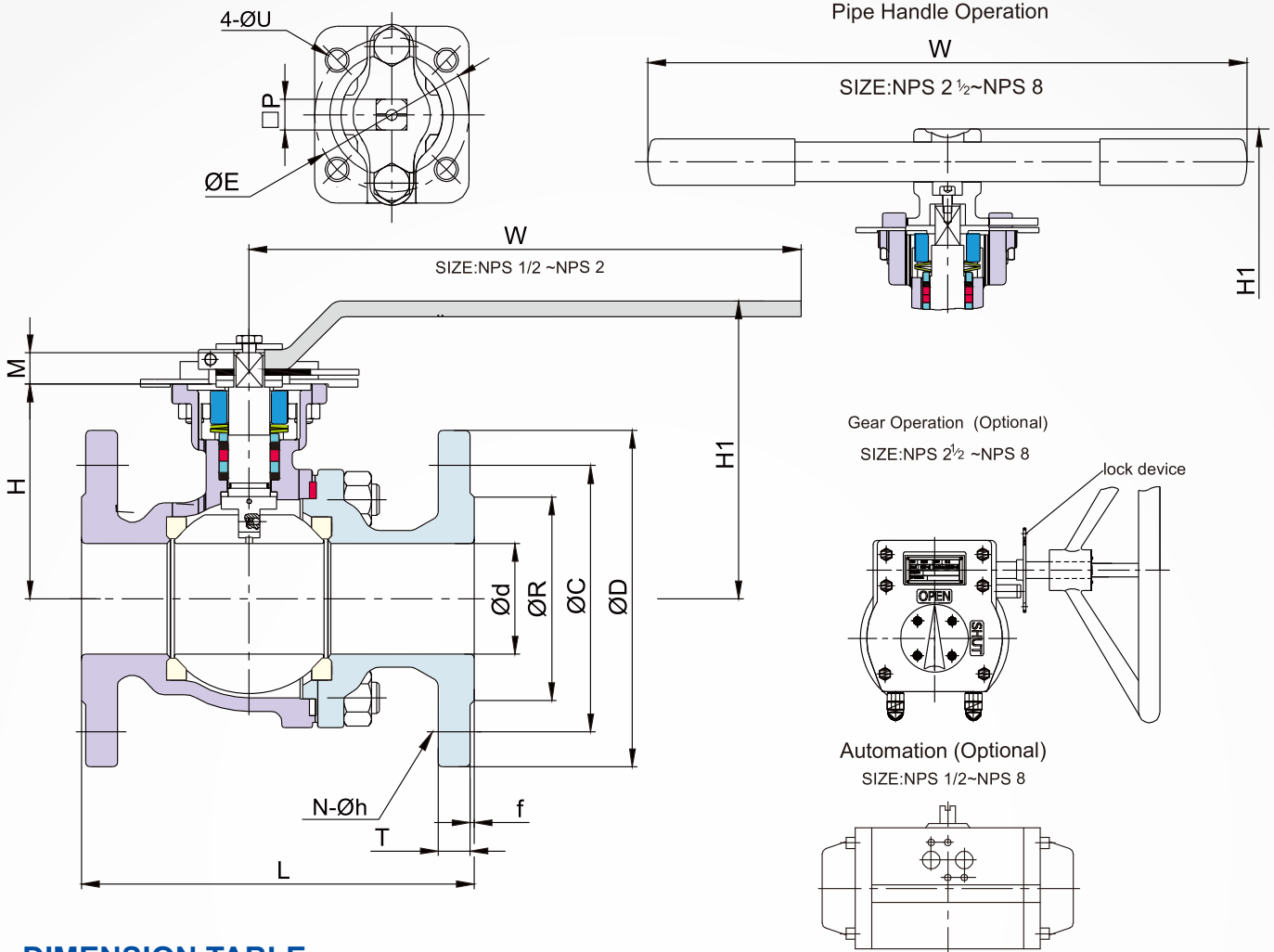

DIMENSION TABLE

ASME Class 150 DIMENSION TABLE KV-L441/KV-L641

Unit : mm

NPS	d	L	R	D	C	T	f	N	h	H	H1	W	P	M	E	U	ISO 5211		
1/2	15	108	35.0	90	60.3	8.0	2	4	16.0	63.5	99	170	9	9.5	—	50	—	8	F05
3/4	20	117	43.0	100	69.9	8.9	2	4	16.0	67	103	170	9	9.5	—	50	—	8	F05
1	25	127	51.0	110	79.4	9.6	2	4	16.0	78	113	200	11	11.5	—	50	—	8	F05
1 1/4	32	140	63.5	115	88.9	11.2	2	4	16.0	82.8	118	200	11	11.5	—	50	—	8	F05
1 1/2	38	165	73.0	125	98.4	12.7	2	4	16.0	91.5	129	250	14	14	—	70	—	9	F07
2	50	178	92.0	150	120.7	14.3	2	4	19.0	97.4	135	250	14	14	—	70	—	9	F07
2 1/2	63.5	190	104.7	180	139.7	15.9	2	4	19.0	137	206	354	17	18	70	102	9	11	F07-F10
3	76	203	127.0	190	152.4	17.5	2	4	19.0	143	212	354	17	18	70	102	9	11	F07-F10
4	100	229	157.0	230	190.5	22.3	2	8	19.0	162	234	404	22	23.5	—	102	—	11	F10
5	125	356	186.0	255	215.9	22.3	2	8	22.3	218	304	804	27	28	125	—	14	—	F12
6	151	394	216.0	280	241.3	23.9	2	8	22.3	238	324	804	27	28	125	—	14	—	F12
8	202	457	270.0	345	298.5	27.0	2	8	22.3	290.5	391	804	36	36	—	140	—	18	F14

ASME Class 150 DIMENSION TABLE KV-L441/KV-L641

Unit : inch

NPS	d	L	R	D	C	T	f	N	h	H	H1	W	P	M	E	U	ISO 5211		
1/2	0.59	4.25	1.38	3.50	2.38	0.31	0.06	4	5/8	2.50	3.88	6.69	0.354	0.37	—	1.97	—	0.31	F05
3/4	0.79	4.62	1.69	3.88	2.75	0.34	0.06	4	5/8	2.64	4.02	6.69	0.354	0.37	—	1.97	—	0.31	F05
1	0.98	5.00	2.01	4.25	3.12	0.38	0.06	4	5/8	3.07	4.49	7.87	0.433	0.45	—	1.97	—	0.31	F05
1 1/4	1.26	5.50	2.50	4.62	3.50	0.44	0.06	4	5/8	3.26	4.69	7.87	0.433	0.45	—	1.97	—	0.31	F05
1 1/2	1.50	6.50	2.88	5.00	3.88	0.50	0.06	4	5/8	3.60	5.08	9.84	0.551	0.55	—	2.76	—	0.35	F07
2	1.97	7.00	3.62	6.00	4.75	0.56	0.06	4	3/4	3.83	5.31	9.84	0.551	0.55	—	2.76	—	0.35	F07
2 1/2	2.50	7.50	4.12	7.00	5.50	0.62	0.06	4	3/4	5.39	8.11	13.9	0.669	0.71	2.76	4.02	0.35	0.43	F07-F10
3	2.99	8.00	5.00	7.50	6.00	0.69	0.06	4	3/4	5.63	8.35	13.9	0.669	0.71	2.76	4.02	0.35	0.43	F07-F10
4	3.94	9.00	6.19	9.00	7.50	0.88	0.06	8	3/4	6.38	9.13	15.9	0.866	0.93	—	4.02	—	0.43	F10
5	4.92	14.00	7.32	10.00	8.50	0.88	0.06	8	7/8	8.58	11.69	31.6	1.063	1.10	4.92	—	0.55	—	F12
6	5.94	15.50	8.50	11.00	9.50	0.94	0.06	8	7/8	9.37	12.91	31.6	1.063	1.10	4.92	—	0.55	—	F12
8	7.95	18.00	10.63	13.50	11.75	1.06	0.06	8	7/8	11.44	15.39	31.6	1.417	1.42	—	5.51	—	0.71	F14

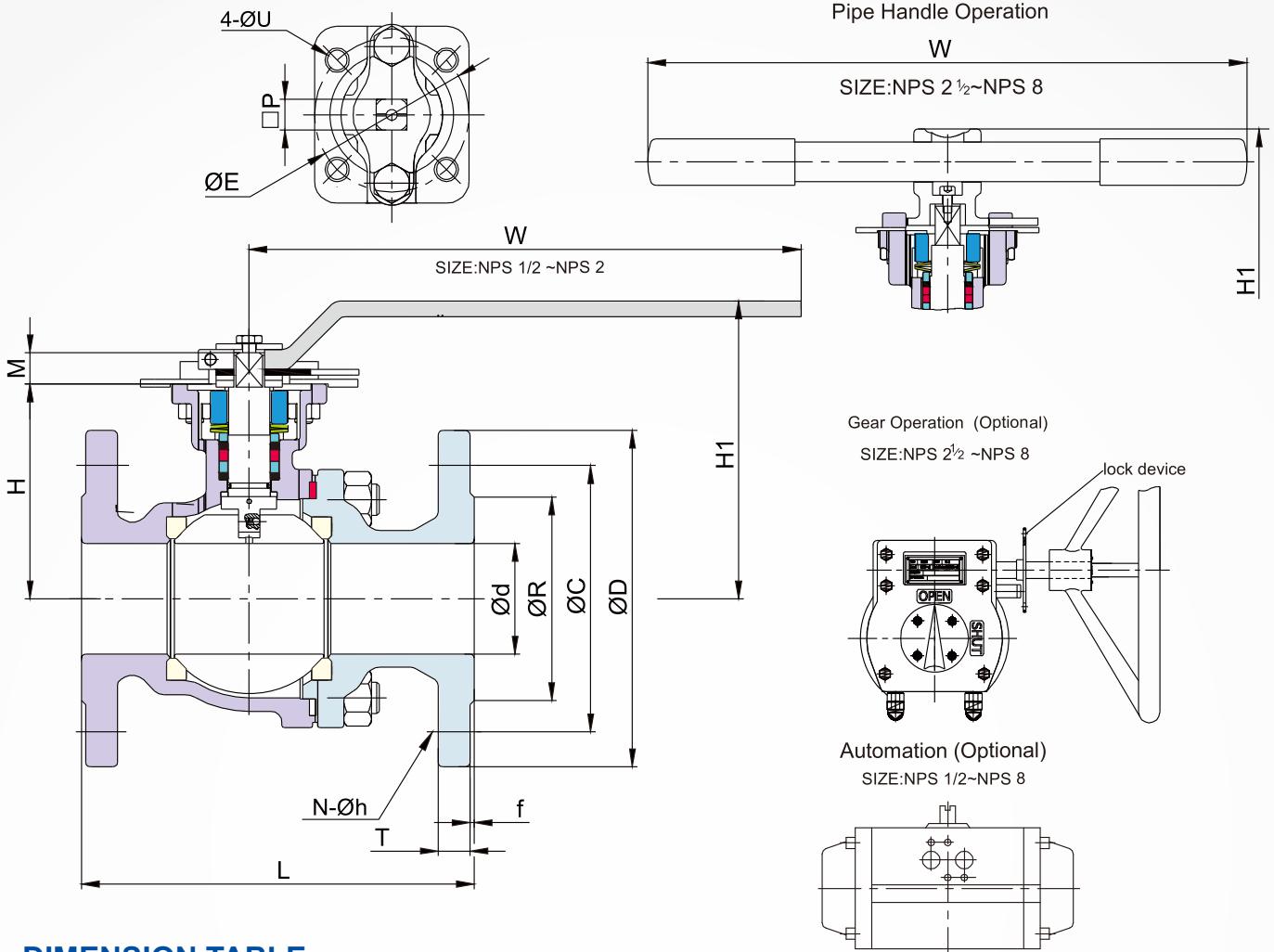

DIMENSION TABLE

ASME Class 300 DIMENSION TABLE KV-L442/KV-L642

Unit : mm

NPS	d	L	R	D	C	T	f	N	h	H	H1	W	P	M	E	U	ISO 5211		
1/2	15	140	35.0	95	66.7	12.7	2	4	16.0	63.5	99	170	9	9.5	—	50	—	8	F05
3/4	20	152	43.0	115	82.6	14.3	2	4	19.0	67	103	170	9	9.5	—	50	—	8	F05
1	25	165	51.0	125	88.9	15.9	2	4	19.0	78	113	200	11	11.5	—	50	—	8	F05
1 1/4	32	178	63.5	135	98.4	17.5	2	4	19.0	82.8	118	200	11	11.5	—	50	—	9	F05
1 1/2	38	190	73.2	155	114.3	19.1	2	4	22.3	91.5	129	250	14	14	—	70	—	9	F07
2	50	216	92.0	165	127.0	20.7	2	8	19.0	97.4	135	250	14	14	—	70	—	9	F07
2 1/2	63.5	241	104.7	190	149.2	23.9	2	8	22.3	137	206	354	17	18	70	102	9	11	F07-F10
3	76	282	127.0	210	168.3	27.0	2	8	22.3	143	212	354	17	18	70	102	9	11	F07-F10
4	100	305	157.0	255	200.0	30.2	2	8	22.3	162	234	404	22	23.5	—	102	—	11	F10
5	125	381	186.0	280	235.0	33.4	2	8	22.3	225	312	804	27	28	125	—	14	—	F12
6	151	403	216.0	320	269.9	35.0	2	12	22.3	238	324	804	27	28	125	—	14	—	F12
8	202	502	270.0	380	330.2	39.7	2	12	25.4	308	409	804	36	36	—	140	—	18	F14

ASME Class 300 DIMENSION TABLE KV-L442/KV-L642

Unit : inch

SIZE	d	L	R	D	C	T	f	N	h	H	H1	W	P	M	E	U	ISO 5211		
1/2	0.59	5.50	1.38	3.75	2.62	0.50	0.06	4	5/8	2.50	3.88	6.69	0.354	0.37	—	1.97	—	0.31	F05
3/4	0.79	6.00	1.69	4.62	3.25	0.56	0.06	4	3/4	2.64	4.02	6.69	0.354	0.37	—	1.97	—	0.31	F05
1	0.98	6.50	2.01	4.88	3.50	0.62	0.06	4	3/4	3.07	4.49	7.87	0.433	0.45	—	1.97	—	0.31	F05
1 1/4	1.26	7.00	2.50	5.25	3.88	0.69	0.06	4	3/4	3.26	4.69	7.87	0.433	0.45	—	1.97	—	0.31	F05
1 1/2	1.50	7.50	2.88	6.12	4.50	0.75	0.06	4	7/8	3.60	5.08	9.84	0.551	0.55	—	2.76	—	0.35	F07
2	1.97	8.50	3.62	6.50	5.00	0.81	0.06	8	3/4	3.83	5.31	9.84	0.551	0.55	—	2.76	—	0.35	F07
2 1/2	2.50	9.50	4.12	7.50	5.88	0.94	0.06	8	7/8	5.39	8.11	13.9	0.669	0.71	2.76	4.02	0.35	0.43	F07-F10
3	2.99	11.12	5.00	8.25	6.62	1.06	0.06	8	7/8	5.63	8.35	13.9	0.669	0.71	2.76	4.02	0.35	0.43	F07-F10
4	3.94	12.00	6.19	10.00	7.88	1.19	0.06	8	7/8	6.38	9.13	15.9	0.866	0.93	—	4.02	—	0.43	F10
5	4.92	15.00	7.32	11.00	9.25	1.31	0.06	8	7/8	8.86	12.28	31.6	1.063	1.10	4.92	—	0.55	—	F12
6	5.94	15.88	8.50	12.50	10.62	1.38	0.06	12	7/8	9.37	12.91	31.6	1.063	1.10	4.92	—	0.55	—	F12
8	7.95	19.75	10.63	15.00	13.00	1.56	0.06	12	1	12.13	16.10	31.6	1.417	1.42	—	5.51	—	0.71	F14