

DESIGN FEATURES

- Built-in ISO 5211 Direct Mounting Pad Easy Automation
- Fire Safe Design Approved
- Anti-static Devices for Ball-Stem-Body
- Blow-out Proof Stem
- Pressure Balance Hole in Ball Slot
- TA-Luft/ ISO 15848-1 Design Approved
- NACE standard MR0175 & MR0103 (Optional)
- Casting Approved by TÜV AD 2000-Merkblatt W0
- Options : 1.Actuator 2.Limit Switch 3.Positioner



APPLICABLE STANDARDS

- Design Standard : MSS SP-110
- Wall Thickness : EN12516-3
- Pipe Thread (KV-L80) : ASME B1.20.1,BS21, EN 10226
DIN 2999/259, ISO 228/1
JIS B0203 ISO7/1
- Butt Weld (KV-L81,KV-L81-L) : ASME B16.25(øB2 Sch80), EN 12627
- Socket Weld (KV-L82) : ASME B 16.11
- Inspection & Testing : MSS SP-110

WEIGHT / CV VALUES

DN	NPS	Weight						CV
		KV-L80		KV-L81		KV-L82		
		(kg)	(lb)	(kg)	(lb)	(kg)	(lb)	
8	1/4	1.10	2.43	1.04	2.29	1.07	2.36	16
10	3/8	1.06	2.34	1.02	2.25	1.04	2.29	23
15	1/2	1.04	2.29	1.00	2.20	1.01	2.23	30
20	3/4	1.50	3.31	1.54	3.40	1.52	3.35	55
25	1	2.10	4.63	2.04	4.50	2.07	4.56	96
32	1 1/4	3.04	6.70	2.94	6.48	3.01	6.64	170
40	1 1/2	4.48	9.88	4.50	9.90	4.49	9.90	270
50	2	7.14	15.74	6.95	15.32	7.06	15.56	460

TORQUE VALUES

 Close to Open Torque at Various Differential Pressure (ΔP), Standard Seats (TFM4215)

unit : in-lb / N-m

Size/ ΔP		75 psig		150 psig		300 psig		700 psig		1000 psig		1500 psig		2000 psig	
		5 bar		10 bar		20 bar		50bar		63bar		100bar		140bar	
DN	NPS	N-m	In-lb	N-m	In-lb	N-m	In-lb	N-m	In-lb	N-m	In-lb	N-m	In-lb	N-m	In-lb
8	1/4	7	62	7	62	7	62	7	62	7	62	7	62	7	62
10	3/8	7	62	7	62	7	62	7	62	7	62	7	62	8	71
15	1/2	7	62	7	62	7	62	7	62	7	62	7	62	8	71
20	3/4	8	71	8	71	8	71	8	71	8	71	8	71	9	80
25	1	13	115	13	115	15	133	15	133	15	133	15	133	16	142
32	1 1/4	17	150	17	150	20	177	22	195	25	221	26	230	—	—
40	1 1/2	25	221	25	221	29	257	31	274	34	301	37	328	—	—
50	2	33	292	33	292	42	372	46	407	49	434	55	487	—	—

Remark :

- 1.The torque figures at 5 bar pressure are maximum values to be tested after the valves are placed for 24 hours.
- 2.For actuator sizing, a safety factor of minimum 30% is recommended.
- 3.If the working temperature is larger than 180°C(356°F), additional safety factor of minimum 20% is recommended.

TECHNICAL INFORMATION

PRESSURE - TEMPERATURE DATA

The pressure-temperature data of ball valves is determined not only by valve shell materials but also by sealing materials used for ball seats, gland packings and flange gaskets.

Floating Ball valves ,2000psi

Full Bore : NPS 1/4 ~ NPS 1

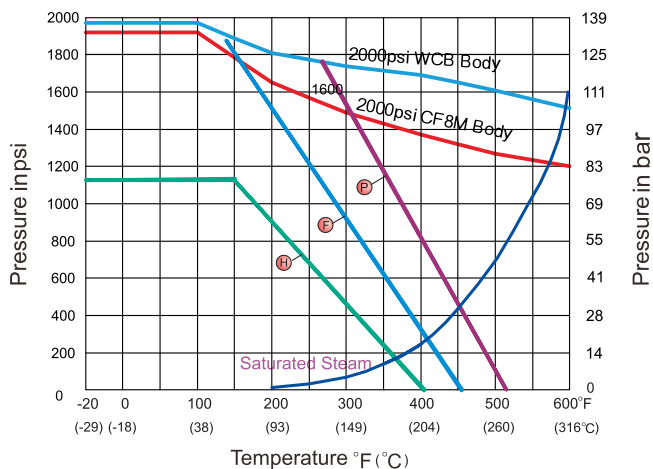

Floating Ball valves ,1500psi

Full Bore : NPS 1 1/4 ~ NPS 2

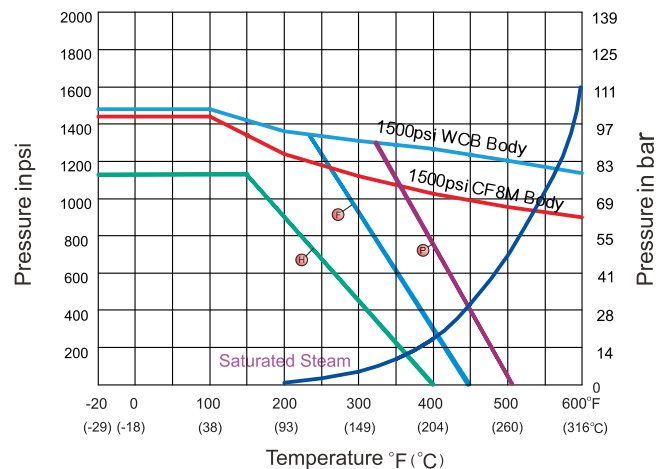

Seat Materials : H TFM1600 E TFM4215 P PEEK

Body Ratings: Shown above are for ASTM A351 Gr.CF8M and A216 Gr.WCB

For ratings of other valve shell materials, please refer to the last edition of ASME B16.34.

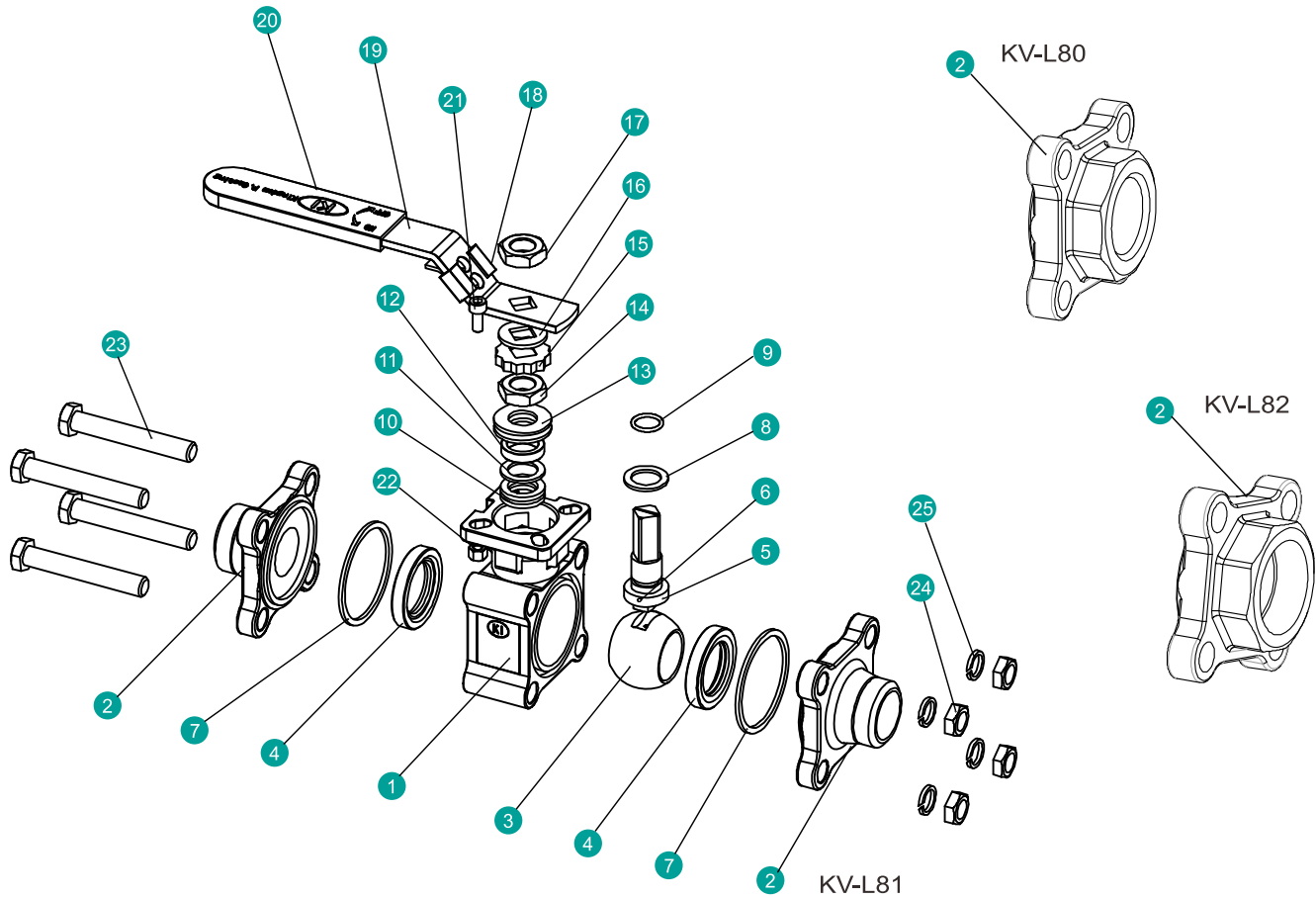

MATERIAL OF CONSTRUCTION

NO.	PART NAME	MATERIALS		
1	Body	CF8M(1.4408)	CF8(1.4308)	WCB(1.0619)
2	End Cap(Thread)	CF8M(1.4408)	CF8(1.4308)	WCB(1.0619)
	End Cap(BW/SW)	CF3M(1.4409)	CF8(1.4308)	WCB(1.0619)
3	Ball	316		304
4	Ball Seat	TFM4215 /TFM1600		
5	Stem	316		304
6	Anti-Static	316		304
7	Body Gasket	PTFE/TFM1600/ GRAPHITE*		
8	Thrust washer	PTFE/TFM1600/ RTFE		
9	O-Ring	FKM		
10	Packing	PTFE/ GRAPHITE*		
11	Bushing	50%SS+50%PTFE / 304*		
12	Gland	316		
13	Belleville Washer	301		
14	Stem Nut	A194-8		
15	Stop-lock-Cap	304		
16	Handle Gland	304		
17	Handle Nut	A194-8		
18	Lock Device	304		
19	Handle	304		
20	Handle Sleeve	PVC		
21	Stop Bolt	A2-70		
22	Stop Nut	A2-70		
23	Bolting	A193-B8/A2-70		
24	Bolt Nut	A193-8/A2-70		
25	Bolt Washer	304		

*Materials for KV-L80F/L81F/L82F/L8FF/L81F-L Series (Fire Safe Models)

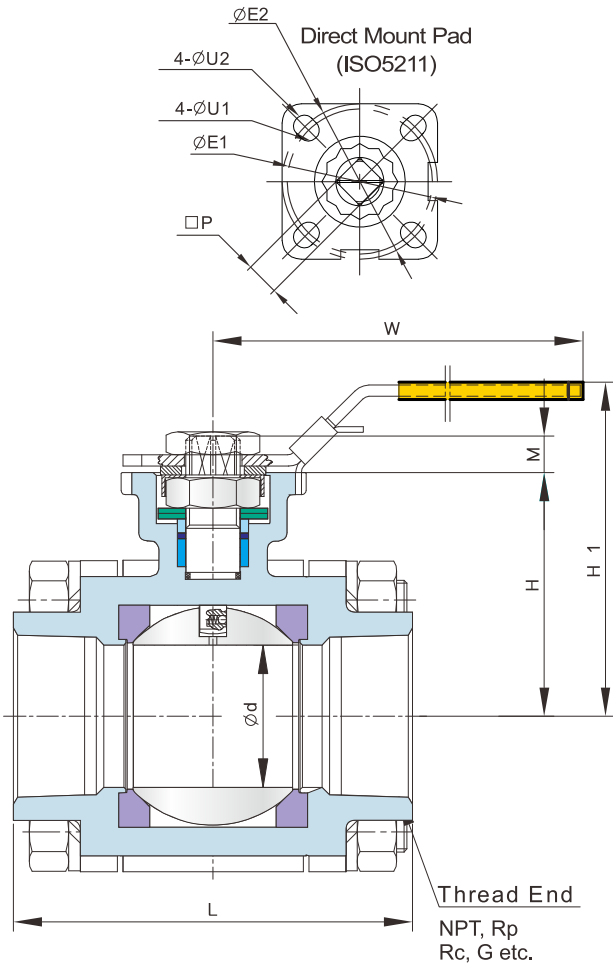

Automation (Optional)

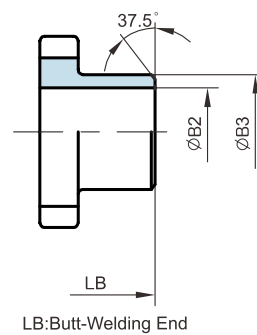
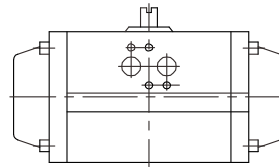

LB:Butt-Welding End

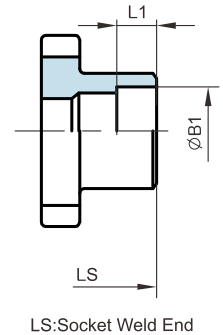

LS:Socket Weld End

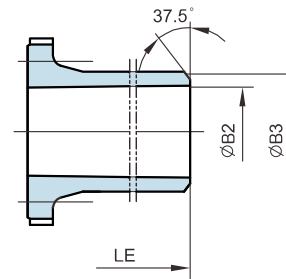

LE:Extended Butt-Welding End

DIMENSION TABLE

ANSI 2000 WOG DIMENSION TABLE

Unit : mm

DN	NPS	d	L	LS	LB	LE	H	H1	W	B1	B2	B3	L1	P	M	E1	E2	U1	U2	HEX.B	ISO 5211
8	1/4	10.6	75	70	70	165	43	73	147	14.2	7.6	18	10.0	9	9	36	42	6	6	23.5	F03~F04
10	3/8	12.7	75	70	70	165	43	73	147	17.8	10.7	18	10.0	9	9	36	42	6	6	23.8	F03~F04
15	1/2	15	75	75	75	165	43	73	147	21.8	13.9	22	10.0	9	9	36	42	6	6	28	F03~F04
20	3/4	20	80	80	90	190	51	81	147	27.3	18.8	28	13.0	9	9	36	50	6	7	34	F03~F05
25	1	25	90	90	100	216	58	88	177	34.0	24.3	34	13.0	11	11	42	50	6	7	46	F03~F05

ANSI 1500 WOG DIMENSION TABLE

Unit : mm

DN	NPS	d	L	LS	LB	LE	H	H1	W	B1	B2	B3	L1	P	M	E1	E2	U1	U2	HEX.B	ISO 5211
32	1 1/4	32	110	110	110	229	63	93	177	42.8	32.5	43	16.0	11	11	42	70	6	9	55	F04~F07
40	1 1/2	38	120	120	125	241	75	107	197	48.9	38.1	50	16.0	14	14	50	70	7	9	57	F05~F07
50	2	50	140	140	150	292	86	118	197	61.4	49.2	61	17.0	14	14	50	70	7	9	73	F05~F07

ANSI 2000 WOG DIMENSION TABLE

Unit : inch

DN	NPS	d	L	LS	LB	LE	H	H1	W	B1	B2	B3	L1	P	M	E1	E2	U1	U2	HEX.B	ISO 5211
8	1/4	0.42	2.95	2.76	2.76	6.50	1.69	2.87	5.79	0.56	0.30	0.71	0.39	0.354	0.28	1.42	1.65	0.24	0.24	0.93	F03~F04
10	3/8	0.50	2.95	2.76	2.76	6.50	1.69	2.87	5.79	0.70	0.42	0.71	0.39	0.354	0.28	1.42	1.65	0.24	0.24	0.93	F03~F04
15	1/2	0.59	2.95	2.95	2.95	6.50	1.69	2.87	5.79	0.86	0.55	0.87	0.39	0.354	0.28	1.42	1.65	0.24	0.24	1.10	F03~F04
20	3/4	0.79	3.15	3.15	3.54	7.50	1.97	3.15	5.79	1.07	0.74	1.10	0.51	0.354	0.35	1.42	1.97	0.24	0.28	1.34	F03~F05
25	1	0.98	3.54	3.54	3.94	8.50	2.28	3.46	6.97	1.33	0.96	1.34	0.51	0.433	0.43	1.65	1.97	0.24	0.28	1.81	F03~F05

ANSI 1500 WOG DIMENSION TABLE

Unit : inch

DN	NPS	d	L	LS	LB	LE	H	H1	W	B1	B2	B3	L1	P	M	E1	E2	U1	U2	HEX.B	ISO 5211
32	1 1/4	1.26	4.33	4.33	4.33	9.00	2.48	3.70	6.97	1.68	1.28	1.69	0.63	0.433	0.43	1.65	2.76	0.24	0.35	2.17	F04~F07
40	1 1/2	1.50	4.72	4.72	4.92	9.50	2.93	4.21	7.76	1.91	1.50	1.97	0.63	0.551	0.55	1.97	2.76	0.28	0.35	2.24	F05~F07
50	2	1.94	5.51	5.51	5.91	11.5	3.35	4.61	7.76	2.41	1.94	2.40	0.67	0.551	0.55	1.97	2.76	0.28	0.35	2.87	F05~F07