

DESIGN FEATURES

- Built-in ISO 5211 Direct Mounting Pad Easy Automation
- Fire Safe Design Approved
- Anti-static Devices for Ball-Stem-Body
- Blow-out Proof Stem
- Pressure Balance Hole in Ball Slot
- TA-Luft/ ISO 15848-1 Design Approved
- NACE standard MR0175 & MR0103 (Optional)
- Casting Approved by TÜV AD 2000-Merkblatt W0
- Options : 1.Actuator 2.Limit Switch 3.Positioner



APPLICABLE STANDARDS

- Design Standard : MSS SP-110
- Wall Thickness : EN12516-3
- Frie Design : API 607 6th 2010, ISO 10497
- Pipe Thread : ASME B1.20.1, BS21, EN 10226
DIN 2999/259, ISO 228/1
JIS B0203 ISO 7/1
- Inspection & Testing : MSS SP-110

WEIGHT / CV VALUES

DN	NPS	CV	Weight	
			(kg)	(lb)
8	1/4	16	0.54	1.19
10	3/8	23	0.55	1.21
15	1/2	30	0.61	1.34
20	3/4	55	0.82	1.81
25	1	96	1.20	2.65
32	1 1/4	170	1.72	3.79
40	1 1/2	270	2.80	6.17
50	2	470	4.22	9.30
65	2 1/2	780	7.35	16.2
80	3	1150	12.7	28.0

TORQUE VALUES

Close to Open Torque at Various Differential Pressure (ΔP), Standard Seats (TFM4215)

unit : in-lb / N-m

Size/ ΔP		75 psig		150 psig		300 psig		700 psig		1000 psig		1500 psig		2000 psig	
		5 bar		10 bar		20 bar		50bar		63bar		100bar		140bar	
DN	NPS	N-m	In-lb	N-m	In-lb	N-m	In-lb	N-m	In-lb	N-m	In-lb	N-m	In-lb	N-m	In-lb
8	1/4	7	62	7	62	7	62	7	62	7	62	7	62	7	62
10	3/8	7	62	7	62	7	62	7	62	7	62	7	62	8	71
15	1/2	7	62	7	62	7	62	7	62	7	62	7	62	8	71
20	3/4	8	71	8	71	8	71	8	71	8	71	8	71	9	80
25	1	13	115	13	115	15	133	15	133	15	133	15	133	16	142
32	1 1/4	17	150	17	150	20	177	22	195	25	221	26	230	—	—
40	1 1/2	25	221	25	221	29	257	31	274	34	301	37	328	—	—
50	2	33	292	33	292	42	372	46	407	49	434	55	487	—	—
65	2 1/2	52	460	59	522	64	566	70	620	77	681	85	752	—	—
80	3	85	752	94	832	105	929	117	1035	131	1159	146	1292	—	—

Remark :

- 1.The torque figures at 5 bar pressure are maximum values to be tested after the valves are placed for 24 hours.
- 2.For actuator sizing, a safety factor of minimum 30% is recommended.
- 3.If the working temperature is larger than 180°C(356°F), additional safety factor of minimum 20% is recommended.

TECHNICAL INFORMATION

PRESSURE - TEMPERATURE DATA

The pressure-temperature data of ball valves is determined not only by valve shell materials but also by sealing materials used for ball seats, gland packings and flange gaskets.

Floating Ball valves ,2000psi

Full Bore : NPS 1/4 ~ NPS 1

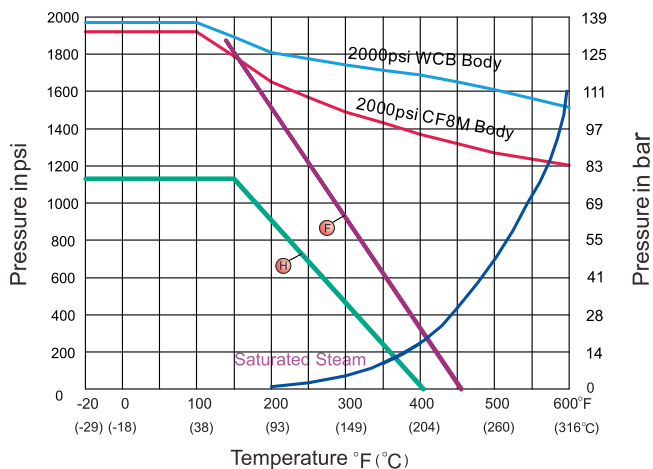

Floating Ball valves ,1500psi

Full Bore : NPS 1 1/4 ~ NPS 3

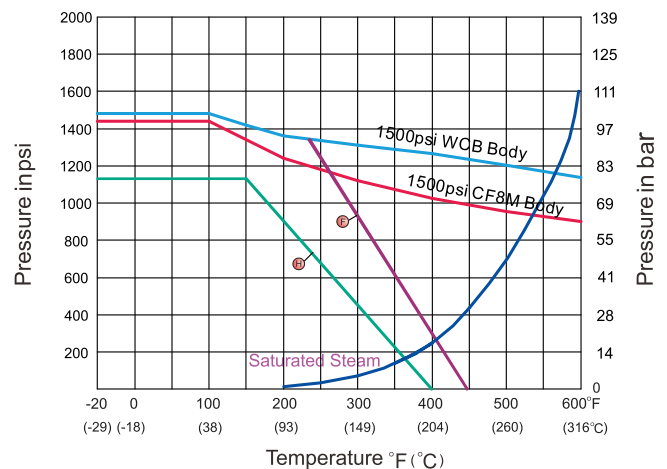

Seat Materials : \textcircled{H} TFM1600 \textcircled{E} TFM4215

Body Ratings: Shown above are for ASTM A351 Gr.CF8M and A216 Gr.WCB

For ratings of other valve shell materials, please refer to the last edition of ASME B16.34.

PRESSURE - TEMPERATURE RATINGS

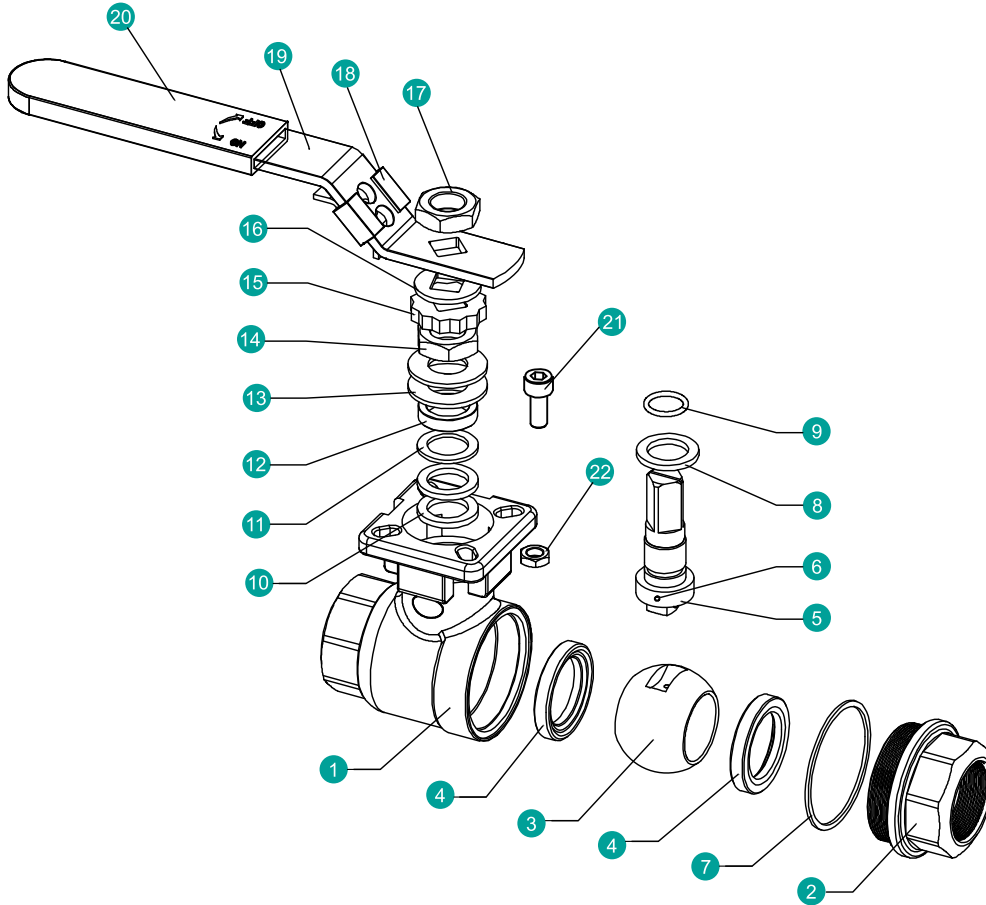

MATERIAL OF CONSTRUCTION

NO.	PART NAME	MATERIALS		
1	Body	CF8M(1.4408)	CF8(1.4308)	WCB(1.0619)
2	End Cap	CF8M(1.4408)	CF8(1.4308)	WCB(1.0619)
3	Ball	316	304	
4	Ball Seat	TFM1600 / TFM4215		
5	Stem	316	304	
6	Anti-Static	316	304	
7	Body Gasket	PTFE / TFM1600 / GRAPHITE*		
8	Thrust washer	PTFE/TFM1600/ RTFE		
9	O-Ring	FKM		
10	Packing	PTFE / GRAPHITE*		
11	Bushing	50%SS+50%PTFE / 304*		
12	Gland	316		
13	Belleville Washer	301		
14	Stem Nut	A194-8		
15	Stop-lock-Cap	304		
16	Handle Gland	304		
17	Handle Nut	A194-8		
18	Lock Device	304		
19	Handle	304		
20	Handle Sleeve	PVC		
21	Stop Bolt	A2-70		
22	Stop Nut	A2-70		

*Materials for KV-L20HF Series (Fire Safe Models)

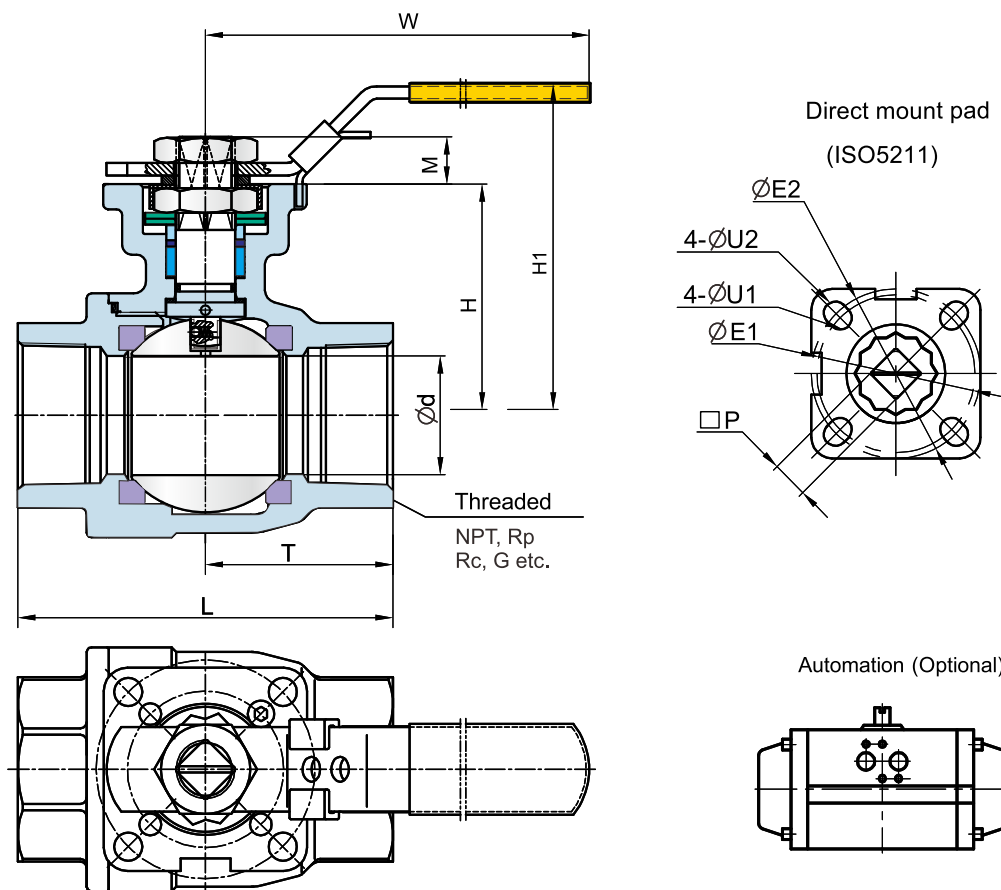

DIMENSION TABLE

ANSI 2000 WOG DIMENSION TABLE

Unit : mm

DN	NPS	d	L	W	H	H1	T	P	M	E1	E2	U1	U2	HEX.B	ISO 5211
8	1/4	10.6	62	147	43.1	74	29	9	9	36	42	6	6	23.5	F03~F04
10	3/8	12.7	62	147	43.1	74	29	9	9	36	42	6	6	23.5	F03~F04
15	1/2	15	75	147	43.1	74	34.5	9	9	36	42	6	6	28	F03~F04
20	3/4	20	80	147	50.7	82	37	9	9	36	50	6	7	33	F03~F05
25	1	25	90	177	58.5	90	45	11	11	42	50	6	7	45	F04~F05

ANSI 1500 WOG DIMENSION TABLE

Unit : mm

DN	NPS	d	L	W	H	H1	T	P	M	E1	E2	U1	U2	HEX.B	ISO 5211
32	1 1/4	32	110	177	63.0	94	51	11	11	42	70	6	9	51	F04~F07
40	1 1/2	38	120	197	73.5	107	60	14	14	50	70	7	9	59	F05~F07
50	2	50	140	197	83.0	117	70	14	14	50	70	7	9	73	F05~F07
65	2 1/2	63.5	185	267	102.3	151	92.5	17	17	70	102	9	11	90	F07~F10
80	3	76	205	267	110.7	160	102.5	17	17	70	102	9	11	104	F07~F10

ANSI 2000 WOG DIMENSION TABLE

Unit : inch

DN	NPS	d	L	W	H	H1	T	P	M	E1	E2	U1	U2	HEX.B	ISO 5211
8	1/4	0.42	2.44	5.79	1.70	2.91	1.14	0.354	0.35	1.42	1.65	0.24	0.24	0.93	F03~F04
10	3/8	0.50	2.44	5.79	1.70	2.91	1.14	0.354	0.35	1.42	1.65	0.24	0.24	0.93	F03~F04
15	1/2	0.59	2.95	5.79	1.70	2.91	1.36	0.354	0.35	1.42	1.65	0.24	0.24	1.10	F03~F04
20	3/4	0.79	3.15	5.79	2.00	3.23	1.46	0.354	0.35	1.42	1.97	0.24	0.28	1.30	F03~F05
25	1	0.98	3.54	6.97	2.30	3.54	1.77	0.433	0.43	1.65	1.97	0.24	0.28	1.77	F04~F05

ANSI 1500 WOG DIMENSION TABLE

Unit : inch

DN	NPS	d	L	W	H	H1	T	P	M	E1	E2	U1	U2	HEX.B	ISO 5211
32	1 1/4	1.26	4.33	6.97	2.48	3.70	2.01	0.433	0.43	1.65	2.76	0.24	0.35	2.01	F04~F07
40	1 1/2	1.50	4.72	7.76	2.91	4.21	2.36	0.551	0.55	1.97	2.76	0.28	0.35	2.32	F05~F07
50	2	1.97	5.51	7.76	3.29	4.61	2.76	0.551	0.55	1.97	2.76	0.28	0.35	2.87	F05~F07
65	2 1/2	2.50	7.28	10.5	4.03	5.94	3.64	0.669	0.67	2.76	4.02	0.35	0.43	3.54	F07~F10
80	3	2.99	8.07	10.5	4.36	6.30	4.04	0.669	0.67	2.76	4.02	0.35	0.43	4.09	F07~F10