

DESIGN FEATURES

- Built-in ISO 5211 Direct Mounting Pad Easy Automation
- ⓧ Anti-static Devices for Ball-Stem-Body
- Blow-out Proof Stem
- Pressure Balance Hole in Ball Slot
- TA-Luft/ ISO 15848-1 Design Approved
- NACE standard MR0175 & MR0103 (Optional)
- Cavity Filled Seat (Optional, KV-L3*-C series)
- Casting Approved by TÜV AD 2000-Merkblatt W0
- Options : 1.Actuator 2.Limit Switch 3.Positioner

APPLICABLE STANDARDS

- Design Standard : MSS SP-110
- Wall Thickness : EN12516-3,
- Pipe Thread (KV-L30) : ASME B1.20.1,BS21, EN 10226
DIN 2999/259, ISO 228/1
JIS B0203 ISO7/1
- Butt Weld (KV-L31,L31-L) : ASME B16.25 (øB2 Sch40), EN 12627
- Socket Weld (KV-L32) : ASME B16.11
- Flange End (KV-L3F*) : ASME B16.5 Class150 KV-L3F(1)
ASME B16.5 Class300 KV-L3F(2)
EN 1092-1 PN10-40 KV-L3F(K/N)
- Inspection & Testing : MSS SP-110



CV / KV VALUES

NPS	DN	CV	KV
1/4	8	16	14
3/8	10	23	20
1/2	15	30	26
3/4	20	55	48
1	25	96	83
1 1/4	32	170	147
1 1/2	40	270	234
2	50	470	407
2 1/2	65	780	675
3	80	1150	995
4	100	2100	1817

WEIGHT

NPS	DN	KV-L30		KV-L31		KV-L32	
		(kg)	(lb)	(kg)	(lb)	(kg)	(lb)
1/4	8	0.64	1.41	0.64	1.41	0.65	1.43
3/8	10	0.65	1.43	0.61	1.34	0.61	1.34
1/2	15	0.68	1.50	0.63	1.39	0.67	1.48
3/4	20	0.95	2.09	0.91	2.01	0.95	2.09
1	25	1.40	3.09	1.35	2.98	1.33	2.93
1 1/4	32	2.21	4.87	2.08	4.59	2.04	4.50
1 1/2	40	2.99	6.59	2.97	6.55	2.80	6.17
2	50	4.50	9.92	4.30	9.48	4.30	9.48
2 1/2	65	8.40	18.5	8.50	18.8	8.30	18.2
3	80	12.3	27.1	12.3	27.1	12.3	27.1
4	100	23.7	52.3	23.4	51.6	23.0	50.7

TORQUE VALUES

Close to Open Torque at Various Differential Pressure (ΔP), Standard Seats (TFM1600 & PTFE)

unit : in-lb / N-m

Size/ ΔP		75 psig		150 psig		300 psig		700 psig		1000 psig	
		5 bar		10 bar		20 bar		50bar		63bar	
NPS	DN	N-m	In-lb	N-m	In-lb	N-m	In-lb	N-m	In-lb	N-m	In-lb
1/4	8	4.5	40	4.5	40	4.5	40	4.5	40	4.5	40
3/8	10	4.5	40	4.5	40	4.5	40	4.5	40	4.5	40
1/2	15	5	44	5	44	5	44	5	44	5	44
3/4	20	6	53	6	53	6	53	6	53	6	53
1	25	10	88	10	89	11	97	11	97	11	97
1 1/4	32	13	115	13	115	15	133	17	150	19	168
1 1/2	40	19	168	19	168	22	195	24	212	26	230
2	50	25	221	29	257	32	283	35	310	38	336
2 1/2	65	40	354	45	398	49	434	54	478	59	522
3	80	65	575	72	637	81	717	90	796	101	894
4	100	100	885	110	973	122	1080	135	1195	148	1310

Remark : 1.Torques will increase about 30% if seat materials are Reinforced Fiber-Glass PTFE, Carbon-filled PTFE or EK+PTFE or TFM4215.

2.The torque figures at 5 bar pressure are maximum values to be tested after the valves are placed for 24 hours.

3.For actuator sizing, a safety factor of minimum 30% is recommended.

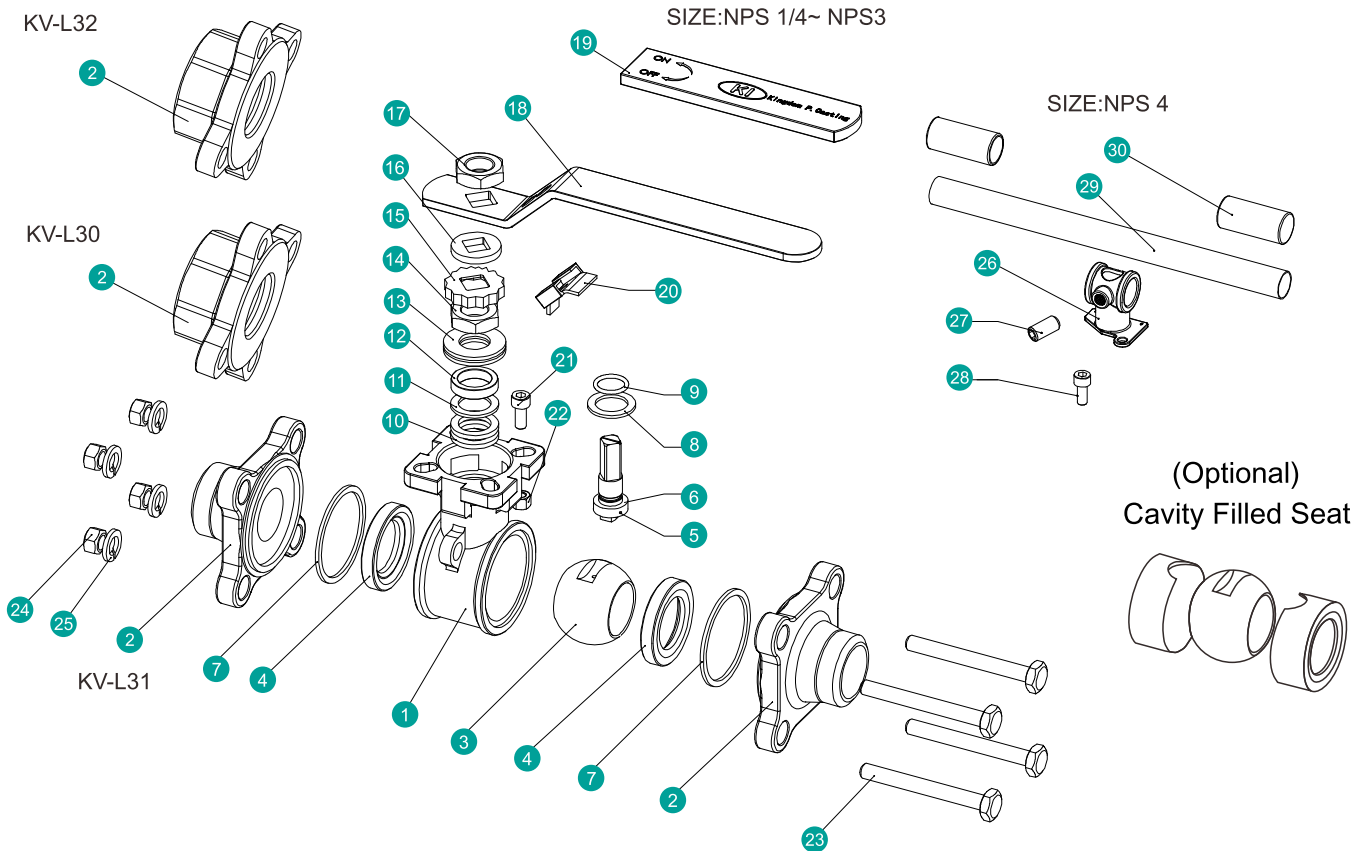

MATERIAL OF CONSTRUCTION

NO.	PART NAME	MATERIALS		
1	Body	CF8M(1.4408)	CF8(1.4308)	WCB(1.0619)
2	End Cap (Thread)	CF8M(1.4408)	CF8(1.4308)	WCB(1.0619)
	End Cap (BW/SW)	CF3M(1.4409)	CF8(1.4308)	WCB(1.0619)
3	Ball	316		304
4	Ball Seat	TFM1600 / PTFE/TFM4215		
5	Stem	316		304
6	Anti-Static	316		304
7	Body Gasket	PTFE / TFM1600		
8	Thrust washer	PTFE / TFM1600 / RTFE		
9	O-Ring	FKM		
10	Packing	PTFE / GRAPHITE*		
11	Bushing	50%SS+50%PTFE / 304		
12	Gland	316		
13	Belleville Washer	301		
14	Stem Nut	A194-8		
15	Stop-lock-Cap	304		
16	Handle Gland	304		
17	Handle Nut (NPS ^{1/4} ~NPS3)	A194-8		
18	Handle (NPS ^{1/4} ~NPS3)	304		
19	Handle Sleeve (NPS ^{1/4} ~NPS3)	PVC		
20	Lock Device (NPS ^{1/4} ~NPS3)	304		
21	Stop Bolt	A2-70		
22	Stop Nut	A2-70		
23	Bolting	A193-B8 / A2-70		
24	Bolt Nut	A194-8 / A2-70		
25	Bolt Washer	304		
26	Handle Adapter (NPS4)	A351-CF8		
27	Set Screwed (NPS4)	A2-70		
28	Bolting (NPS4)	A2-70		
29	Pipe Handle (NPS4)	A53+PLATED Zn		
30	Handle Sleeve (NPS4)	PVC		

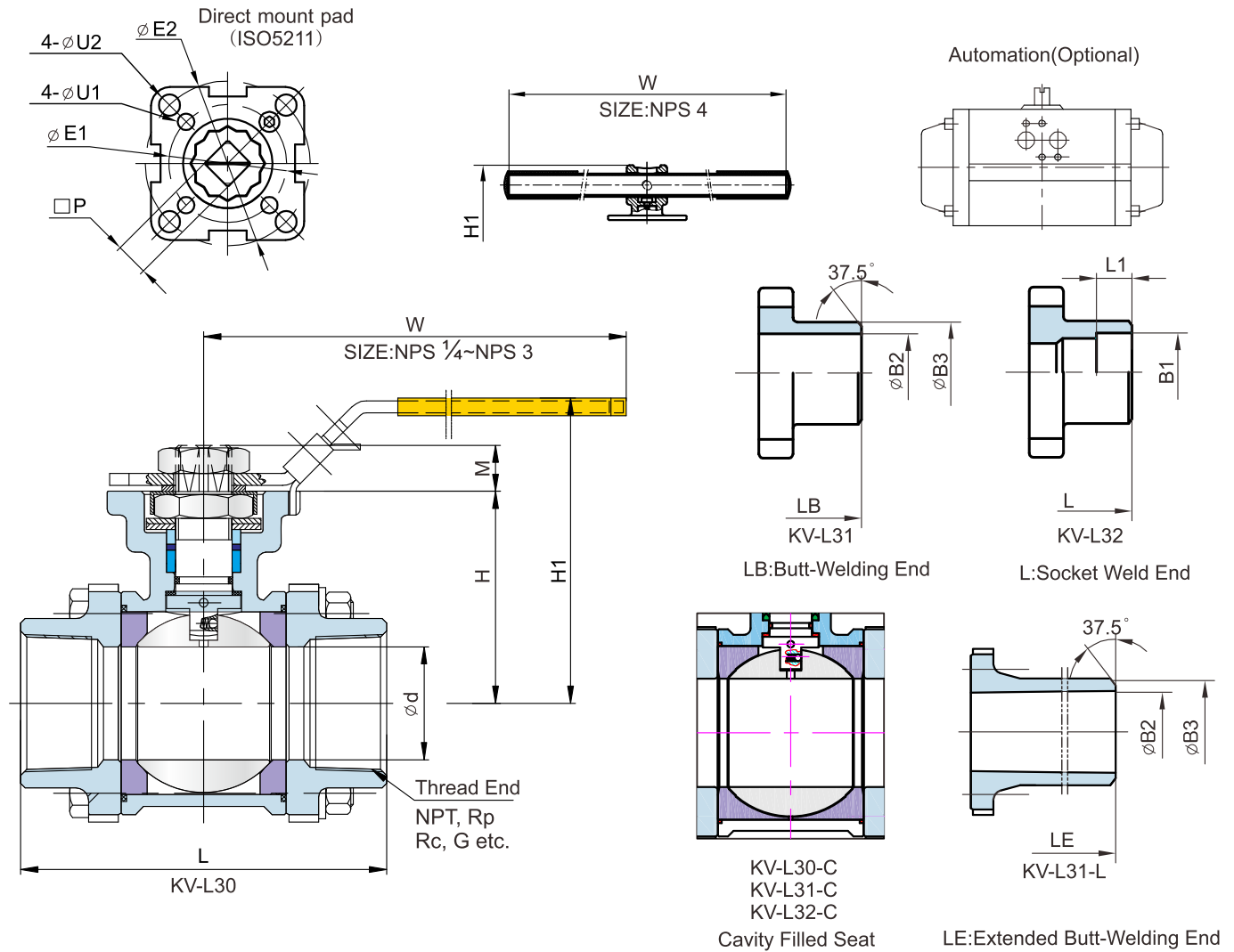

DIMENSION TABLE

ANSI 1000 WOG DIMENSION TABLE

Unit : mm

NPS	DN	d	L	LB	LE	H	H1	W	B1	B2	B3	L1	P	M	E1	E2	U1	U2	HEX.B	ISO 5211
1/4	8	10.6	75	70	225	42	72	147	14.2	9.3	18	10.0	9	9	36	42	6	6	28	F03-F04
3/8	10	12.7	75	70	225	42	72	147	17.8	12.5	18	10.0	9	9	36	42	6	6	28	F03-F04
1/2	15	15	75	75	225	42	72	147	21.8	15.8	22	10.0	9	9	36	42	6	6	28	F03-F04
3/4	20	20	80	90	225	48.5	79	147	27.3	20.9	28	13.0	9	9	36	50	6	7	34.5	F03-F05
1	25	25	90	100	245	58.5	89	177	34.0	26.7	34	13.0	11	11	42	50	6	7	42	F04-F05
1 1/4	32	32	110	110	255	63	93	177	42.8	35.1	43	16.0	11	11	42	70	6	9	52	F04-F07
1 1/2	40	38	120	125	260	71.3	103	197	48.9	40.9	50	16.0	14	14	50	70	7	9	58.5	F05-F07
2	50	50	140	150	275	78.2	110	197	61.4	52.5	61	17.0	14	14	50	70	7	9	71.5	F05-F07
2 1/2	65	63.5	185	190	330	100	150	267	74.0	62.7	76	17.0	17	17	70	102	9	11	86.5	F07-F10
3	80	76	205	220	356	108.5	159	267	90.0	78.0	92	17.0	17	17	70	102	9	11	101	F07-F10
4	100	100	240	270	432	140	212	400	115.5	102.4	115	20.0	22	22	—	102	—	11	132	F10

Unit : inch

NPS	DN	d	L	LB	LE	H	H1	W	B1	B2	B3	L1	P	M	E1	E2	U1	U2	HEX.B	ISO 5211
1/4	8	0.42	2.95	2.76	8.86	1.65	2.83	5.79	0.55	0.37	0.71	0.39	0.354	0.28	1.42	1.65	0.24	0.24	1.10	F03-F04
3/8	10	0.50	2.95	2.76	8.86	1.65	2.83	5.79	0.70	0.49	0.71	0.39	0.354	0.28	1.42	1.65	0.24	0.24	1.10	F03-F04
1/2	15	0.59	2.95	2.95	8.86	1.65	2.83	5.79	0.86	0.62	0.87	0.39	0.354	0.28	1.42	1.65	0.24	0.24	1.10	F03-F04
3/4	20	0.79	3.15	3.54	8.86	1.91	3.11	5.79	1.07	0.82	1.10	0.51	0.354	0.35	1.42	1.97	0.24	0.28	1.36	F03-F05
1	25	0.98	3.54	3.94	9.65	2.30	3.50	6.97	1.34	1.05	1.34	0.51	0.433	0.43	1.65	1.97	0.24	0.28	1.65	F04-F05
1 1/4	32	1.26	4.33	4.33	10.04	2.48	3.66	6.97	1.69	1.38	1.69	0.63	0.433	0.43	1.65	2.76	0.24	0.35	2.05	F04-F07
1 1/2	40	1.50	4.72	4.92	10.24	2.81	4.06	7.76	1.93	1.61	1.97	0.63	0.551	0.55	1.97	2.76	0.28	0.35	2.30	F05-F07
2	50	1.97	5.51	5.91	10.83	3.08	4.33	7.76	2.42	2.07	2.40	0.67	0.551	0.55	1.97	2.76	0.28	0.35	2.81	F05-F07
2 1/2	65	2.50	7.28	7.48	12.99	3.94	5.91	10.5	2.91	2.47	2.99	0.67	0.669	0.67	2.76	4.02	0.35	0.43	3.41	F07-F10
3	80	2.99	8.07	8.66	14.02	4.27	6.26	10.5	3.54	3.07	3.62	0.67	0.669	0.67	2.76	4.02	0.35	0.43	3.98	F07-F10
4	100	3.94	9.45	10.63	17.01	5.51	8.35	15.9	4.55	4.03	4.53	0.79	0.866	0.87	—	4.02	—	0.43	5.20	F10

*M3 Face to Face dimensions are available

*For valves with butt weld ends per DIN11850 series 2 or ISO1127, the pressure rating will be 400 WOG.

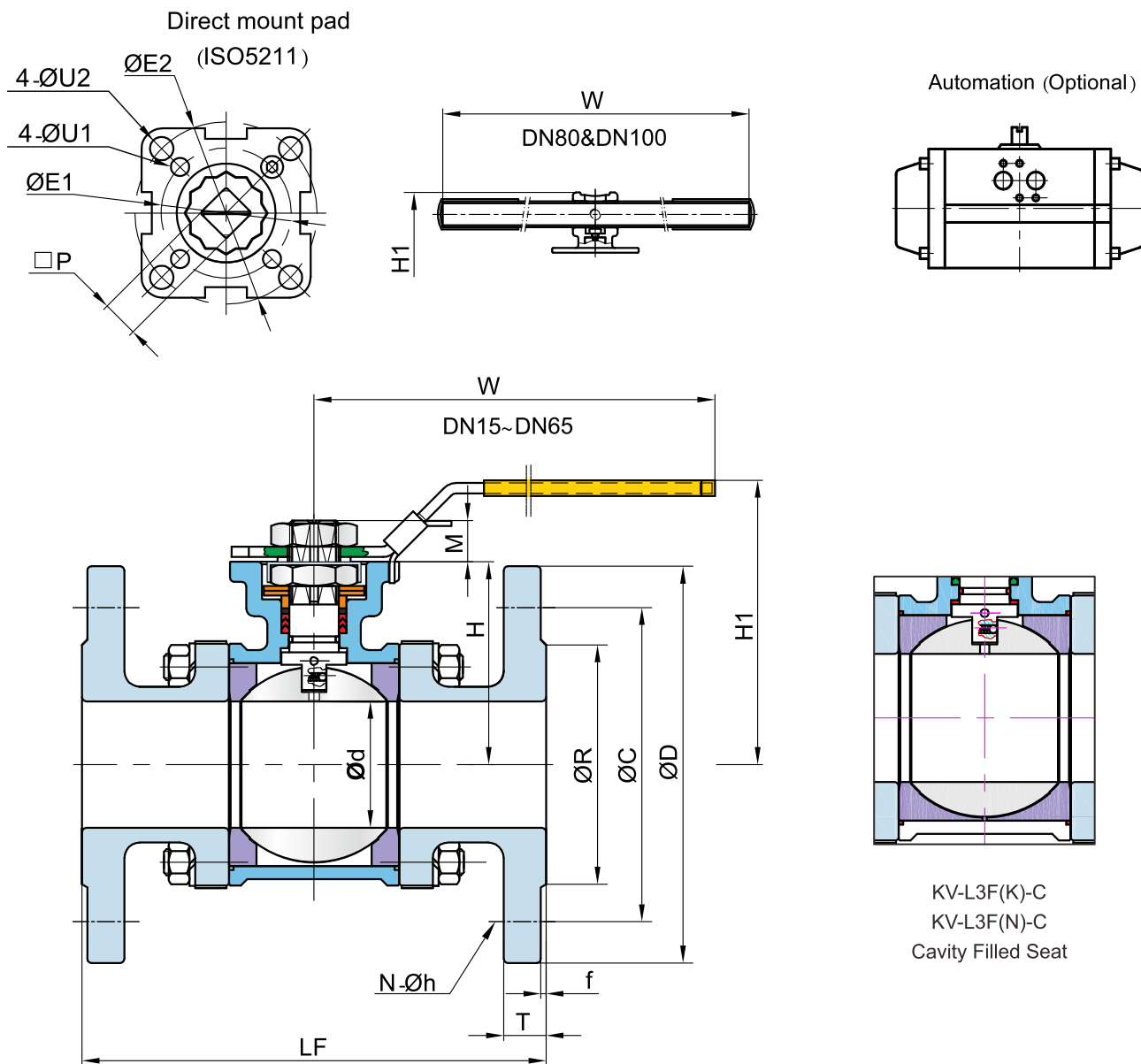

DIMENSION TABLE

EN PN10/16/25/40 DIMENSION TABLE

Unit : mm

DN	PN	d	LF	R	D	C	f	T	N	h	H	H1	W	P	M	E1	E2	U1	U2	ISO5211
15	10	15	130	45	95	65	2	16	4	14	42	72	147	9	9	36	42	6	6	F03-F04
20		20	150	58	105	75	2	18	4	14	48.5	79	147	9	9	36	50	6	7	F03-F05
25	16	25	160	68	115	85	2	18	4	14	58.5	89	177	11	11	42	50	6	7	F04-F05
32	25	32	180	78	140	100	2	18	4	18	63	94	177	11	11	42	70	6	9	F04-F07
40		38	200	88	150	110	3	18	4	18	71.3	103	197	14	14	50	70	7	9	F05-F07
50	40	50	230	102	165	125	3	20	4	18	78.2	110	197	14	14	50	70	7	9	F05-F07
65	10/16	63.5	290	122	185	145	3	18	4 ^(a)	18	100	150	267	17	17	70	102	9	11	F07-F10
	22							8												
80	10/16	76	310	138	200	160	3	20	8	18	109	174	300	17	17	70	102	9	11	F07-F10
	24							8												
100	10/16	100	350	158	220	180	3	20	8	18	140	212	400	22	22	NON	102	NON	11	F10
	162			235				190												

KV-L3F(K) [PN16] KV-L3F(N) [PN40]

(a): 4 holes is factory standard for DN65 PN16 valve and 8 holes is optional.

**ASME Class 150, High Performance
3 - PC Body, Full Port, Flanged Ends Ball valve**

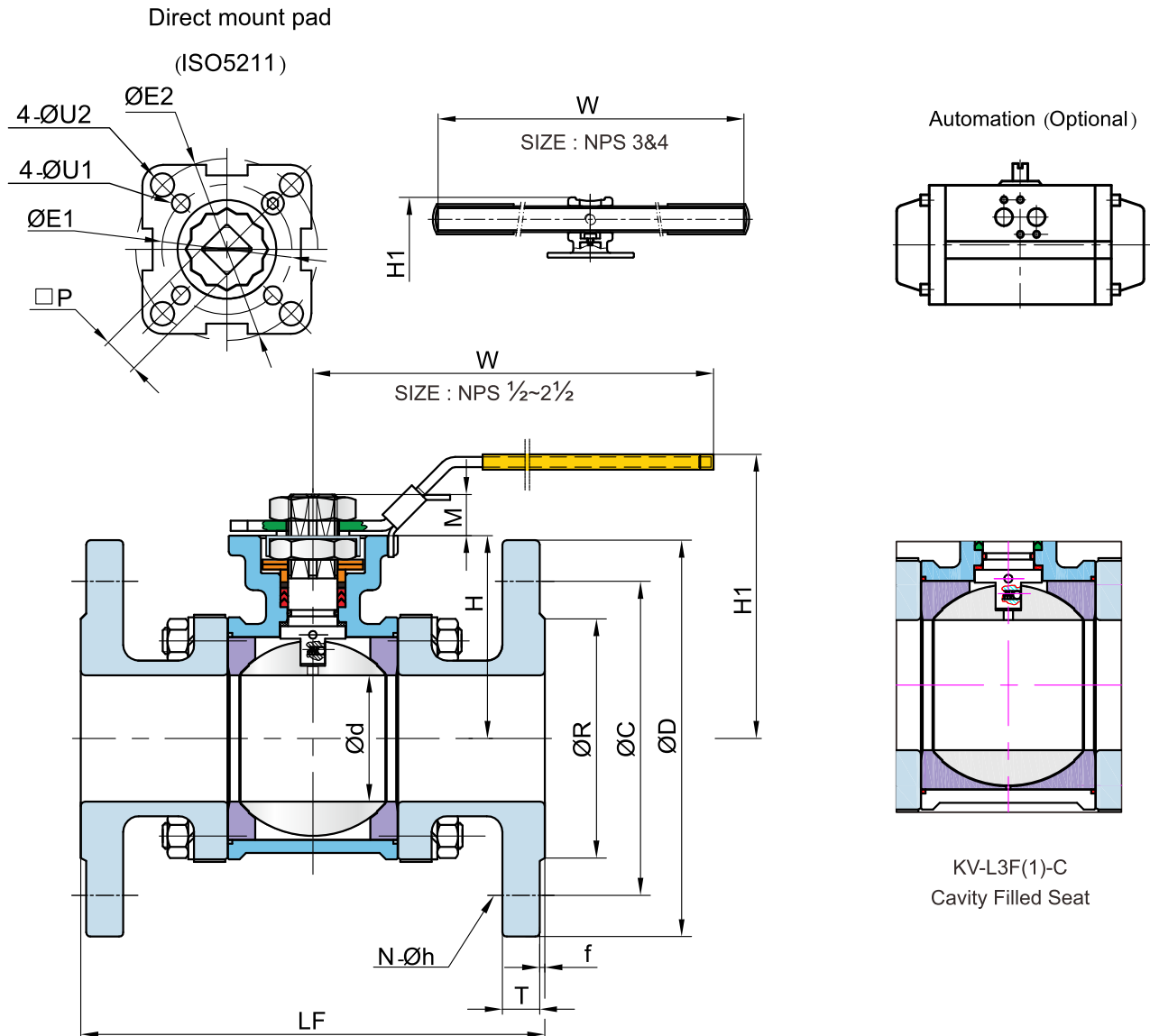

■ ASME Class 150 DIMENS ON TABLE

Unit : mm

NPS	d	LF	R	D	C	f	T	N	h	H	H1	W	P	M	E1	E2	U1	U2	ISO5211
1/2	15	130	35.0	90	60.3	2	8.0	4	16.0	42	72	147	9	9	36	42	6	6	F03~F04
3/4	20	150	43.0	100	69.9	2	8.9	4	16.0	48.5	79	147	9	9	36	50	6	7	F03~F05
1	25	160	51.0	110	79.4	2	9.6	4	16.0	58.5	89	177	11	11	42	50	6	7	F04~F05
1 1/4	32	180	63.5	115	88.9	2	11.2	4	16.0	63	94	177	11	11	42	70	6	9	F04~F07
1 1/2	38	200	73.2	125	98.4	2	12.7	4	16.0	71.3	103	197	14	14	50	70	7	9	F05~F07
2	50	230	92.0	150	120.7	2	14.3	4	19.0	78.2	110	197	14	14	50	70	7	9	F05~F07
2 1/2	63.5	290	104.7	180	139.7	2	15.9	4	19.0	100	150	267	17	17	70	102	9	11	F07~F10
3	76	310	127.0	190	152.4	2	17.5	4	19.0	109	174	300	17	17	70	102	9	11	F07~F10
4	100	350	157.0	230	190.5	2	22.3	8	19.0	140	212	400	22	22	—	102	—	11	F10

Unit : inch

NPS	d	L	R	D	C	f	T	N	h	H	H1	W	P	M	E1	E2	U1	U2	ISO5211
1/2	0.59	5.12	1.38	3.50	2.38	0.06	0.31	4	5/8	1.65	2.83	5.79	0.354	0.28	1.42	1.65	0.24	0.24	F03~F04
3/4	0.79	5.91	1.69	3.88	2.75	0.06	0.34	4	5/8	1.91	3.11	5.79	0.354	0.35	1.42	1.97	0.24	0.28	F03~F05
1	0.98	6.30	2.01	4.25	3.12	0.06	0.38	4	5/8	2.30	3.50	6.97	0.433	0.43	1.65	1.97	0.24	0.28	F04~F05
1 1/4	1.26	7.09	2.50	4.62	3.50	0.06	0.44	4	5/8	2.48	3.66	6.97	0.433	0.43	1.65	2.76	0.24	0.35	F04~F07
1 1/2	1.50	7.87	2.88	5.00	3.88	0.06	0.50	4	5/8	2.81	4.06	7.76	0.551	0.55	1.97	2.76	0.28	0.35	F05~F07
2	1.97	9.06	3.62	6.00	4.75	0.06	0.56	4	3/4	3.08	4.33	7.76	0.551	0.55	1.97	2.76	0.28	0.35	F05~F07
2 1/2	2.50	11.42	4.12	7.00	5.50	0.06	0.62	4	3/4	3.94	5.91	10.5	0.669	0.67	2.76	4.02	0.35	0.43	F07~F10
3	2.99	12.20	5.00	7.50	6.00	0.06	0.69	4	3/4	4.27	6.85	11.9	0.669	0.67	2.76	4.02	0.35	0.43	F07~F10
4	3.94	13.78	6.19	9.00	7.50	0.06	0.88	8	3/4	5.51	8.35	15.9	0.866	0.87	—	4.02	—	0.43	F10

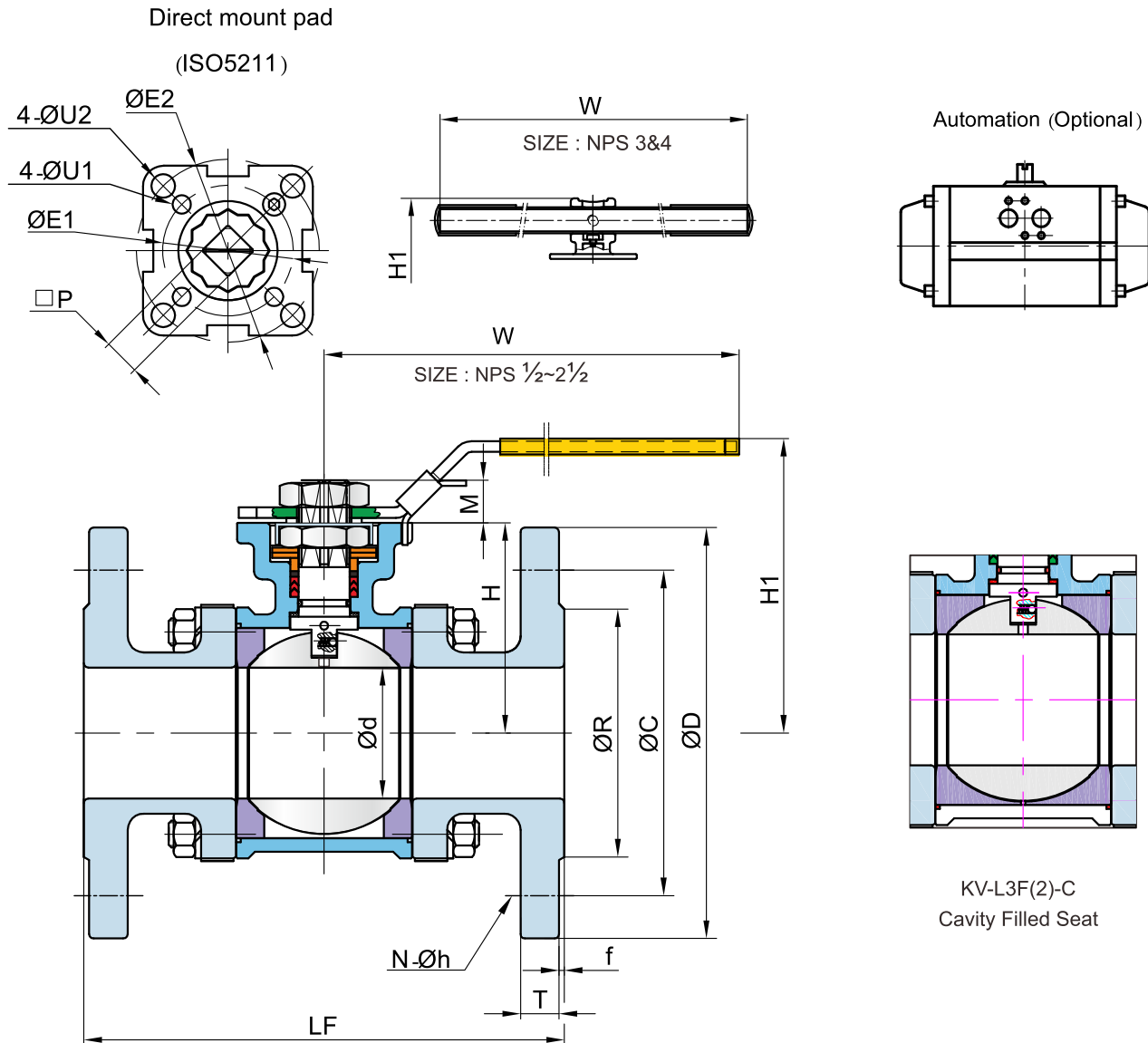

ASME Class 300 DIMENSION TABLE

Unit : mm

NPS	d	LF	R	D	C	f	T	N	h	H	H1	W	P	M	E1	E2	U1	U2	ISO5211
1/2	15	130	35.0	95	66.7	2	12.7	4	16.0	42	72	147	9	9	36	42	6	6	F03~F04
3/4	20	150	43.0	115	82.6	2	14.3	4	19.0	48.5	79	147	9	9	36	50	6	7	F03~F05
1	25	160	51.0	125	88.9	2	15.9	4	19.0	58.5	89	177	11	11	42	50	6	7	F04~F05
1 1/4	32	180	63.5	135	98.4	2	17.5	4	19.0	63	94	177	11	11	42	70	6	9	F04~F07
1 1/2	38	200	73.2	155	114.3	2	19.1	4	22.3	71.3	103	197	14	14	50	70	7	9	F05~F07
2	50	230	92.0	165	127.0	2	20.7	8	19.0	78.2	110	197	14	14	50	70	7	9	F05~F07
2 1/2	63.5	290	104.7	190	149.2	2	23.9	8	22.3	100	150	267	17	17	70	102	9	11	F07~F10
3	76	310	127.0	210	168.3	2	27.0	8	22.3	109	174	300	17	17	70	102	9	11	F07~F10
4	100	350	157.0	255	200.0	2	30.2	8	22.3	140	212	400	22	22	—	102	—	11	F10

Unit : inch

NPS	d	L	R	D	C	f	T	N	h	H	H1	W	P	M	E1	E2	U1	U2	ISO5211
1/2	0.59	5.12	1.38	3.75	2.62	0.06	0.50	4	5/8	1.65	2.83	5.79	0.354	0.28	1.42	1.65	0.24	0.24	F03~F04
3/4	0.79	5.91	1.69	4.62	3.25	0.06	0.56	4	3/4	1.91	3.11	5.79	0.354	0.35	1.42	1.97	0.24	0.28	F03~F05
1	0.98	6.30	2.01	4.88	3.50	0.06	0.62	4	3/4	2.30	3.50	6.97	0.433	0.43	1.65	1.97	0.24	0.28	F04~F05
1 1/4	1.26	7.09	2.50	5.25	3.88	0.06	0.69	4	3/4	2.48	3.66	6.97	0.433	0.43	1.65	2.76	0.24	0.35	F04~F07
1 1/2	1.50	7.87	2.88	6.12	4.50	0.06	0.75	4	7/8	2.81	4.06	7.76	0.551	0.55	1.97	2.76	0.28	0.35	F05~F07
2	1.97	9.06	3.62	6.50	5.00	0.06	0.81	8	3/4	3.08	4.33	7.76	0.551	0.55	1.97	2.76	0.28	0.35	F05~F07
2 1/2	2.50	11.42	4.12	7.50	5.88	0.06	0.94	8	7/8	3.94	5.91	10.5	0.669	0.67	2.76	4.02	0.35	0.43	F07~F10
3	2.99	12.20	5.00	8.25	6.62	0.06	1.06	8	7/8	4.27	6.85	11.9	0.669	0.67	2.76	4.02	0.35	0.43	F07~F10
4	3.94	13.78	6.19	10.00	7.88	0.06	1.19	8	7/8	5.51	8.35	15.9	0.866	0.87	—	4.02	—	0.43	F10

TECHNICAL INFORMATION

PRESSURE - TEMPERATURE DATA

Floating Ball Valves, 1000psi

The pressure-temperature data of ball valves is determined not only by valve shell materials but also by sealing materials used for ball seats, gland packings and flange gaskets.

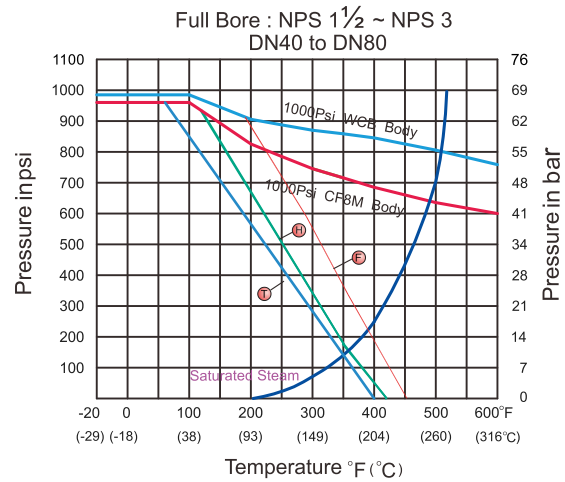
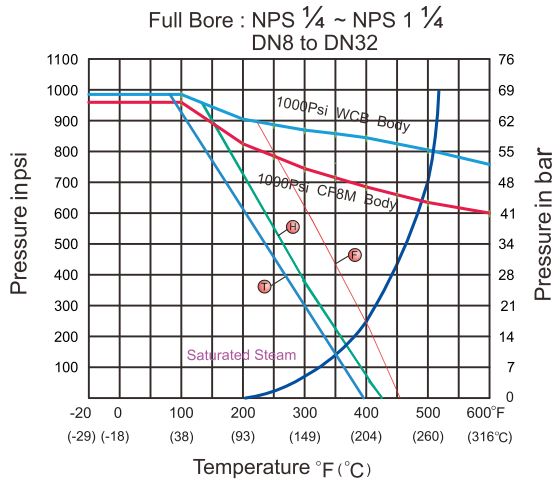

Floating Ball Valves, EN PN16/40

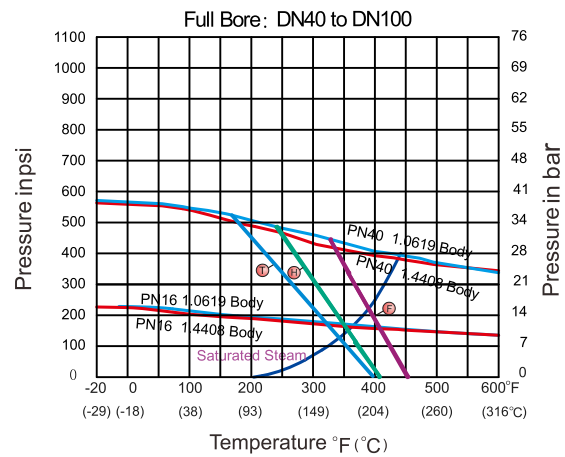
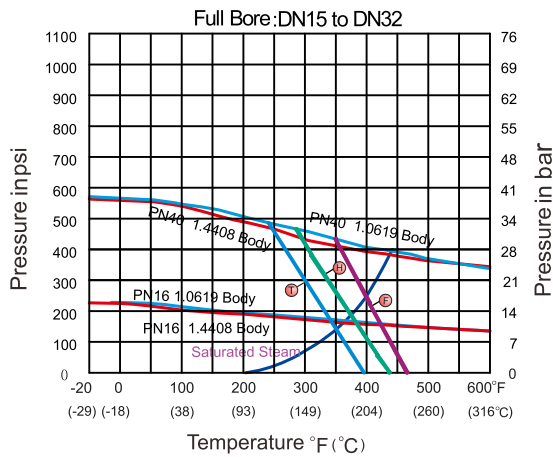

Floating Ball Valves, ASME Class 150/300

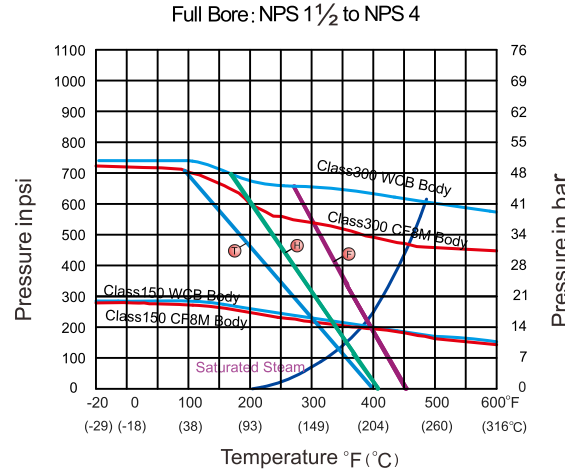
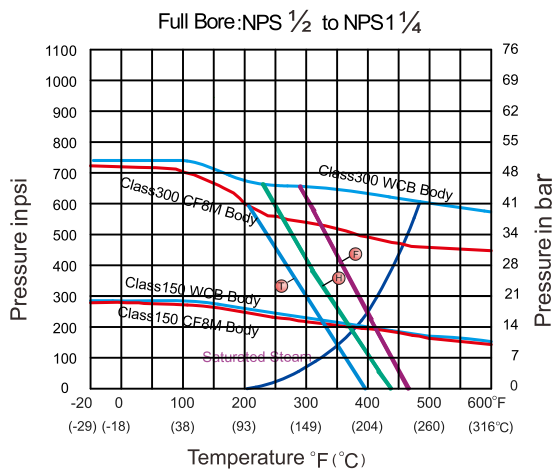

Seat Materials : T PTFE H TFM1600 E TFM4215

Body Ratings: Shown above are for ASTM A351 Gr.CF8M and A216 Gr.WCB

For ratings of other valve shell materials, please refer to the last edition of ASME B16.34.